



150W / 200W / 250W
SSPBM-X 2200-G series



Features

- Output power of 150W / 200W / 250W in a single compact package
- High linearity
- Full M&C capability via RS485 or Ethernet port (optional)
- Weatherproof construction
- CE marking
- MIL-STD-188-164A latest revision compliant

Overview

Based on GaN technology the new G-Series X-Band BUCs provide high power density in a compact size. Combined with the traditional Advantech Wireless features, these new series of BUCs provide the ultimate in performance and convenience. The products in the new G-Series X-Band BUCs are available as SSPA or SSPB (BUC). The first products available in the new G-Series are 150W, 200W and 250W.

Options

- Ethernet port
- 70 dB Receive Reject Filter (external)
- Harmonic filter (external)

Accessories

- Mounting kits
- External Receive Reject Filter
- External Transmit Reject Filter (for RX path)
- Remote M&C panel with optional SNMP
- Flexible and rigid waveguides
- Mounting frames
- High power terminations
- Replacement fans

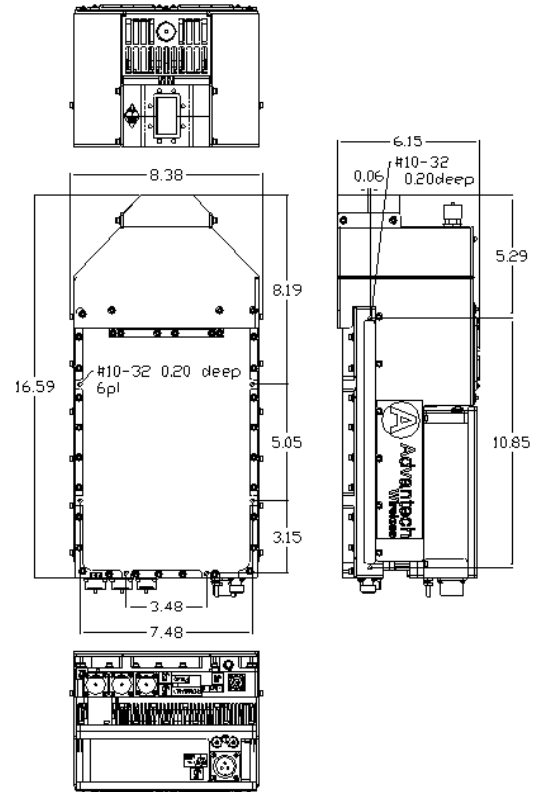

Figure 1: Outline drawing

150W / 200W / 250W X-Band SSPB GaN

General Specifications						
	150W		200W		250W	
Operating Frequency	7.9 – 8.4 GHz					
L-Band input (BUC)	950 – 1450 MHz					
Output Power	P _{SAT} +52.0 dBm min	P _{SAT} +53.0 dBm min	P _{SAT} +54.0 dBm min	P _{LINEAR} +48.0 dBm	P _{LINEAR} +49.0 dBm	P _{LINEAR} +50.0 dBm
Gain	74dB ± 3 dB					
Gain adjustment range	20 dB in 0.1 dB steps					
Gain flatness over full band	4 dB p-p max					
Gain slope over 40 MHz	1dB p-p dB max					
Gain variation over temperature	± 1.5 dB max					
Input Impedance and VSWR	50 Ω 1.3:1					
Output VSWR	1.25:1 with optional Output Isolator					
Noise power density	-75 dBm/Hz in Transmit Band, -110 dBm/Hz in Receive Band (7.25 – 7.75 GHz) -145 dBm/Hz with optional external Receive Reject Filter					
Spurious	-55 dBc max at P _{LINEAR}					
Harmonics	-40 dBc @ P _{LINEAR}					
AM/PM conversion	1°/dB at P _{LINEAR}					
Third order intermod (two tones)	-25 dBc two signal 5 MHz apart at P _{LINEAR}					
Spectral regrowth	30 dBc @ P _{LINEAR}					
Group delay	Ripple 1 nsec p-p max					
Local Oscillator freq.	6.95 GHz					
Phase Noise	-53 dBc/Hz at 10Hz -63 dBc/Hz at 100Hz -73 dBc/Hz at 1000Hz		-83 dBc/Hz at 10 kHz -95 dBc/Hz at 100 kHz			
External Reference Frequency phase noise (max)	10 MHz -120 dBc/Hz at 10Hz -135 dBc/Hz at 100Hz -150 dBc/Hz at 1000Hz		-155 dBc/Hz at 10 kHz -160 dBc/Hz at 100 kHz			
Weight & Dimensions						
Dimensions	16.6" x 8.5" x 5.5" (406 x 200 x 140 mm)					
Weight	30 lbs. (13.6 kg)					
Input voltage	DC 48V (40v – 60V) AC 90 – 265 VAC (47 – 63 Hz)					
Power consumption (nominal)	1100W at Psat, 900W at P _{LINEAR}					
Interfaces	Input (L-Band) DC line RS485/Ethernet	N type female MS3102 type MS3112 type	RF output AC line	CPR112 MS3102 type		
Environmental	Temperature	Operating -30°C to +55 °C Storage -55°C to +85 °C		Option 1 -40°C to +55 °C		
	Humidity	100% condensing				
	Altitude	10,000' AMSL, de-rated by 2 °C/1000' from AMSL				

NORTH AMERICA
USA
Tel: +1 703 659 9796
Fax: +1 703 635 2212
info.usa@advantechwireless.com

CANADA
Tel: +1 514 420 0045
Fax: +1 514 420 0073
info.canada@advantechwireless.com

EUROPE
UNITED KINGDOM
Tel: +44 1480 357 600
Fax: +44 1480 357 601
info.uk@advantechwireless.com

RUSSIA & CIS
Tel: +7 495 971 59 18
info.russia@advantechwireless.com

INDIA
Tel: +91 33 2415 5922
info.india@advantechwireless.com

SOUTH AMERICA
Tel: +1 514 420 0045
Fax: +1 514 420 0073
info.latam@advantechwireless.com

BRAZIL
Tel: +55 11 3054 5701
Fax: +55 11 3054 5701
info.brazil@advantechwireless.com

An ISO 9001 : 2008 Company



Ref.: PB-SSPBg-X-150-200-250W-13150