

## X-Band 500 kW Crossed-Field Amplifier

### SFD251

#### Features:

- Frequency: 9.5 - 10.0 GHz
- Peak Power: 500 kW
- Duty Cycle: 0.001
- Pulsewidth: 0.5  $\mu$ Sec
- Anode voltage 34 kV
- Cold cathode
- Water cooled anode

#### Benefits:

- High peak power
- Wide bandwidth



#### Applications:

- Ground based radar

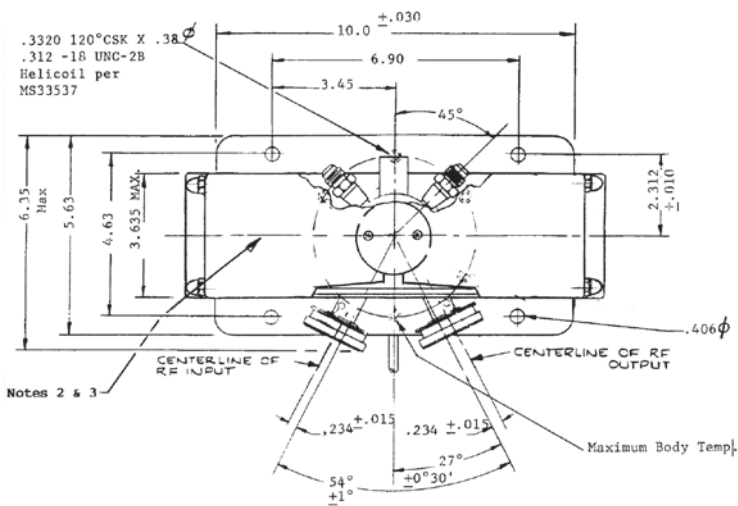
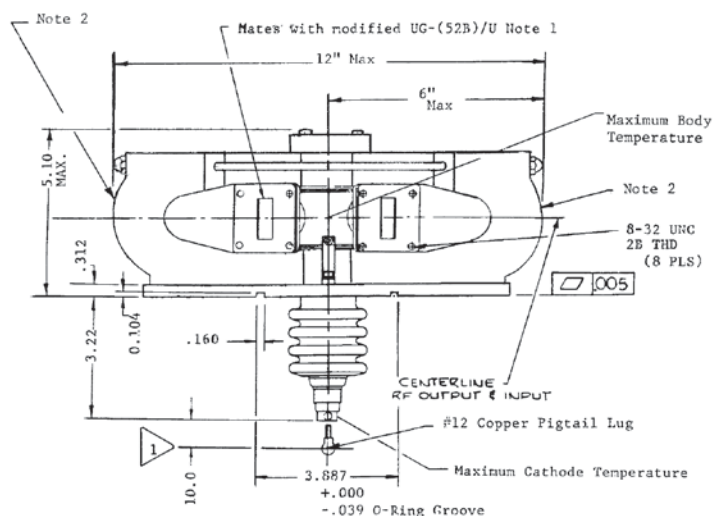

The values listed above represent specified limits for the product and are subject to change. The data should be used for basic information only. Formal, controlled specifications may be obtained from CPI for use in equipment design.

For information on this and other CPI products visit our webpage at [www.cpii.com/bmd](http://www.cpii.com/bmd), or contact: CPI Beverly Microwave Division, +1 (978) 922-6000 • FAX: +1 (978) 922-8914 • [bmdmarketing@cpil.com](mailto:bmdmarketing@cpil.com)