



125W Ku-Band 3RU SSPA Chassis

Description

Teledyne Paradise Datacom's Indoor, Compact Rack Mount (CRM) series Solid State Power Amplifiers represent the latest in High Power Microwave Amplifier Technology. The SSPA chassis achieves the highest power density in the industry along with enhanced maintainability.

The power supply, fan trays and controller card connector plate are all removable for easy maintenance. At 24" deep, and only 3RU high, this chassis is perfect for SNG applications, or other configurations where rack space is at a premium.

The SSPA front panel features an easy-to-navigate display and menu structure. Dedicated LEDs are provided for alarm condition indication.

Teledyne Paradise Datacom rack mount power amplifiers have a wide range of monitor and control functionality, including:

- RS-232/RS-485 (4-wire) serial communication
- Ethernet port supporting UDP, SNMP and web browser-based control
- Form C contacts for output monitor ports and opto-isolated input ports
- Free Windows M&C software
- Variety of third party M&C drivers available

FEATURES

- Power Levels to:
300W C-Band;
200W X-Band;
150W Ku-Band
- Removable Power Supply, Fan Tray and Monitor & Control Assembly
- Ethernet Port
- RF Output Sample Port
- 20 dB Gain Adjustment
- CE Compliant
- Universal, Power Factor Corrected Power Supply
- Built-in 1:1 Redundancy Control
- Built-in Maintenance Switch Controller

OPTIONS

- Remote Control Panel
- L-Band Input operation
- Reflected Power Monitor
- Input Sample Port
- 1RU Redundant Power Supply
- Exhaust Duct Adapters
- Redundant Systems
- Phase Combined Systems

C-Band 3RU SSPA Chassis

PARAMETER	NOTES	LIMITS	UNITS
Frequency Range	(see options for extended band)	5.850 to 6.425	GHz
Output Power @: Saturation/ P_{1dB} (Typical/Guaranteed minimum)	HPAC3050ARXXXXX HPAC3075ARXXXXX HPAC3100ARXXXXX HPAC3140ARXXXXX HPAC3200ARXXXXX HPAC3250ARXXXXX HPAC3300ARXXXXX	P_{sat} / P_{1dB} 47.0 (50) / 46.8 (48) 48.8 (76) / 48.5 (70) 50.0 (100) / 49.5 (89) 51.5 (141) / 51.0 (125) 53.0 (200) / 52.3 (170) 54.0 (250) / 53.0 (200) 54.7 (300) / 54.0 (250)	dBm (W) dBm (W) dBm (W) dBm (W) dBm (W) dBm (W) dBm (W)
Power Requirements Line Frequency Line Power (Voltage) (typical @ 220 VAC)	power factor corrected HPAC3050ARXXXXX HPAC3075ARXXXXX HPAC3100ARXXXXX HPAC3140ARXXXXX HPAC3200ARXXXXX HPAC3250ARXXXXX HPAC3300ARXXXXX	47 to 63 400 (90 to 265) 450 (90 to 265) 650 (90 to 265) 850 (90 to 265) 1000 (180 to 265) 1300 (180 to 265) 1700 (180 to 265)	Hz W (VAC) W (VAC) W (VAC) W (VAC) W (VAC) W (VAC) W (VAC)

Frequency Options

Extended Frequency Bands 5.850 to 6.725 GHz 5.75 to 6.67 GHz	De-rate output power by 1.0dB Linearly from 6.425 to 6.725 GHz De-rate output power by 1.0dB Linearly from 6.425 to 6.67 GHz and by 0.5 dB linearly from 5.85 to 5.75 GHz
--	--

X-Band 3RU SSPA Chassis

PARAMETER	NOTES	LIMITS	UNITS
Frequency Range	(see options for extended band)	7.90 to 8.40	GHz
Output Power @: Saturation/ P_{1dB} (Typical/Guaranteed minimum)	HPAX3060ARXXXXX HPAX3075ARXXXXX HPAX3100ARXXXXX HPAX3140ARXXXXX HPAX3200ARXXXXX	P_{sat} / P_{1dB} 47.5 (60) / 47.3 (54) 48.8 (76) / 48.3 (68) 50.0 (100) / 49.5 (89) 51.4 (140) / 50.8 (120) 53.0 (200) / 51.8 (151)	dBm (W) dBm (W) dBm (W) dBm (W) dBm (W)
Power Requirements Line Frequency Line Power (Voltage) (typical @ 220 VAC)	power factor corrected HPAX3060ARXXXXX HPAX3075ARXXXXX HPAX3100ARXXXXX HPAX3140ARXXXXX HPAX3200ARXXXXX	47 to 63 650 (90 to 265) 700 (90 to 265) 750 (90 to 265) 1225 (90 to 265) 1370 (180 to 265)	Hz W (VAC) W (VAC) W (VAC) W (VAC) W (VAC)

Frequency Options

Extended Frequency Band 7.50 to 8.50 GHz 9.50 to 10.50 GHz 7.70 to 8.40 GHz	De-rate output power by 1.0dB Linearly from 7.90 to 7.70 GHz
--	--

Indoor Rack Mount GaAs Solid State Power Amplifier 3RU Rack Height

Ku-Band 3RU SSPA Chassis

PARAMETER	NOTES	LIMITS	UNITS
Frequency Range	(see options for extended band)	14.00 to 14.50	GHz
Output Power @: Saturation/ P_{1dB} (Typical/Guaranteed minimum)	HPAK3025ARXXXXX HPAK3035ARXXXXX HPAK3040ARXXXXX HPAK3050ARXXXXX HPAK3070ARXXXXX HPAK3100ARXXXXX HPAK3125ARXXXXX	P_{sat} / P_{1dB} 44.0 (25) / 43.0 (20) 45.5 (35) / 44.5 (28) 46.0 (40) / 45.0 (31) 47.0 (50) / 46.0 (40) 48.5 (70) / 47.5 (56) 50.0 (100) / 49.0 (80) 51.0 (125) / 50.0 (100)	dBm (W) dBm (W) dBm (W) dBm (W) dBm (W) dBm (W) dBm (W)
Power Requirements Line Frequency Line Power (Voltage) (typical @ 220 VAC)	power factor corrected HPAK3025ARXXXXX HPAK3035ARXXXXX HPAK3040ARXXXXX HPAK3050ARXXXXX HPAK3070ARXXXXX HPAK3100ARXXXXX HPAK3125ARXXXXX	47 to 63 320 (90 to 265) 350 (90 to 265) 500 (90 to 265) 500 (90 to 265) 650 (90 to 265) 1100 (180 to 265) 1200 (180 to 265)	Hz W (VAC) W (VAC) W (VAC) W (VAC) W (VAC) W (VAC) W (VAC)

Frequency Options

Extended Frequency Band 13.75 to 14.50 GHz	De-rate output power by 1.0dB linearly from 14.00 to 13.75 GHz
---	--

Common Electrical Specifications, 3RU SSPA Chassis

PARAMETER	NOTES	LIMITS	UNITS
Gain	Adjustable range	55-75	dB
Gain Flatness	full band (All except Extended C-Band)	± 1.0	dB
	Extended C-Band units	± 1.5	dB
Gain Slope	per 40 MHz	± 0.3	dB/40 MHz
Gain Variation vs. Temperature	0°C to +50°C	± 1.0	dB
Gain Stability	at constant temperature	± 0.25	dB/24 hours
Gain Adjustment Resolution	in 0.1 dB steps	20	dB
Intermodulation Distortion	3 dB back off relative to P _{1dB}	-25	dBc
AM/PM Conversion	(@ rated P _{1dB})	3.5	°/dB
	(@P _{1dB} - 3 dB)	1.0	°/dB
Spurious Harmonics	(@ rated P _{1dB})	-65	dBc
	(@ rated P _{1dB} - 3 dB)	-50	dBc
Input/Output VSWR	Extended C-Band	1.30:1	
	Output VSWR: Ku-Band with bulkhead filter	1.50:1	
		1.40:1	
Noise Figure	at maximum gain	12	dB
Group Delay	Linear	0.01	ns/MHz
	Parabolic	0.003	ns/MHz ²
	Ripple	1.0	ns p-p
Noise Output	TX Band	-75	dBW/4 KHz
	RX Band (C- or Ku-Band)	-150	dBW/4 KHz
	RX Band (X-Band)	-100	dBW/4 KHz
Residual AM Noise	0 - 10 KHz	-45	dBc
	10 KHz - 500 KHz	-20 (1.25 + log F)	dBc
	500 KHz - 1 MHz	-80	dBc
Residual Phase Noise	Offset frequency from carrier		
	10 Hz	-90	dBc/Hz
	100 Hz	-100	dBc/Hz
	1 KHz	-110	dBc/Hz
	10 KHz	-120	dBc/Hz
	100 KHz	-125	dBc/Hz
	1 MHz	-130	dBc/Hz

Mechanical

Size	width X height X depth	19.0 X 5.22 X 24.13 483 X 133 X 613	inches mm
Weight		66 (30) 77 (35)	lbs. (kg) lbs. (kg)
Finish		powder coat	Gray

Environmental

Operating Temperature	Ambient	0 to +50	°C
Relative Humidity	non-condensing	95	%
Cooling System	Forced Convection Air Cooling	Front Panel - Intake Rear Panel - Exhaust	

Specifications are subject to change.

L-Band Operation

Teledyne Paradise Datacom amplifiers are available with an integrated L-Band Block Up Converter. L-Band units utilize Teledyne Paradise Datacom's proprietary zBUC technology. The addition of a zBUC[®] converter to the SSPA typically increases the gain by 2-4 dB. The advantages of zBUC technology include:

- zBUC converter can detect and switch to an externally supplied reference.
- Optional internal high stability (10MHz) reference.
- zBUC converter can lock to an externally supplied reference of 10 or 50 MHz.
- zBUC converter can accept a wide range of external reference power (-10 to +5 dBm).

Available Frequency Plans

Band	Frequency Band	IF Input	LO Frequency	RF Output	Gain Change
C	Standard C-Band	950 - 1525 MHz	4.900 GHz	5.850 - 6.425 GHz	0-4 dB
C	Extended C-Band	950 - 1825 MHz	4.900 GHz	5.850 - 6.725 GHz	0-4 dB
C	Palapa Band	950 - 1250 MHz	5.475 GHz	6.425 - 6.725 GHz	0-4 dB
C	Insat Band	950 - 1250 MHz	5.775 GHz	6.725 - 7.025 GHz	0-4 dB
C	Extended C-Band 2	950 - 1675 MHz	4.800 GHz	5.750 - 6.475 GHz	0-4 dB
C	Low C-Band	840 - 1000 MHz	4.250 GHz	5.090 - 5.250 GHz	0-4 dB
X	Standard X-Band	950 - 1450 MHz	6.950 GHz	7.900 - 8.400 GHz	0-2 dB
Ku	Standard Ku-Band	950 - 1450 MHz	13.050 GHz	14.00 - 14.50 GHz	0-2 dB
Ku	Extended Ku-Band	950 - 1700 MHz	12.800 GHz	13.75 - 14.50 GHz	0-2 dB

Electrical Specifications for 3RU RM SSPA with ZBUC converter

PARAMETER	NOTES	LIMITS				UNITS
Gain	Nominal setting	75				dB
Gain Flatness	full band (C-,X-,Ku-bands)	± 2.0				dB
Gain Slope	per 40 MHz (C-,X-,Ku-bands)	± 0.5				dB/40 MHz
Gain Adjusted Range		20				dB
	Typical C-Band Adj. Range	60 - 80				dB
	Typical Ku-Band Adj. Range	57 - 77				dB
Gain Stability	-40 to +60 °C	± 1.5				dB
Phase Noise	Offset frequency from carrier	<u>Absolute max.</u>	<u>C-band (typ.)</u>	<u>X-band (typ.)</u>	<u>Ku-band (typ.)</u>	
	10 Hz	-30	-60	-60	-50	dBc/Hz
	100 Hz	-60	-80	-75	-65	dBc/Hz
	1 KHz	-70	-80	-75	-72	dBc/Hz
	10 KHz	-80	-85	-100	-90	dBc/Hz
	100 KHz	-90	-120	-110	-110	dBc/Hz
	1 MHz	-90	-125	-122	-120	dBc/Hz
Spurious	In-Band Signal Related (C-/Ku-Band) (Extended C-Band)	-50				dBc
	Close to Carrier Spurious (≤ 20 MHz)	-40				dBc
	Local Oscillator	-50				dBc
		-30				dBm
Noise Figure	At 75 dB gain setting	20				dB
Input VSWR	L-Band	1.5 : 1				
Internal Reference Option	Reference Accuracy (initial)	± 1 • 10 ⁻⁸				
	Aging per day (after 30 days)	± 1 • 10 ⁻⁹				
	Aging per year (after 30 days)	± 6 • 10 ⁻⁸				
	Reference Stability over Temperature (-40 to +40 °C, ambient)	± 1 • 10 ⁻⁸				

Indoor Rack Mount GaAs Solid State Power Amplifier 3RU Rack Height

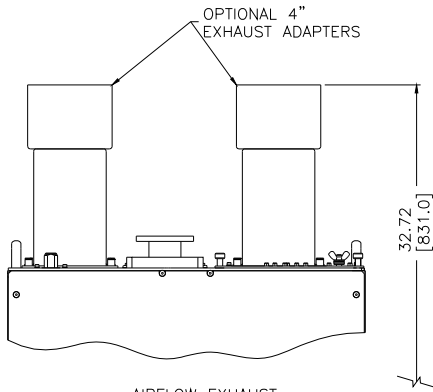

Direct heat generated by the SSPA away from the unit with the optional 4.0" exhaust adapters.

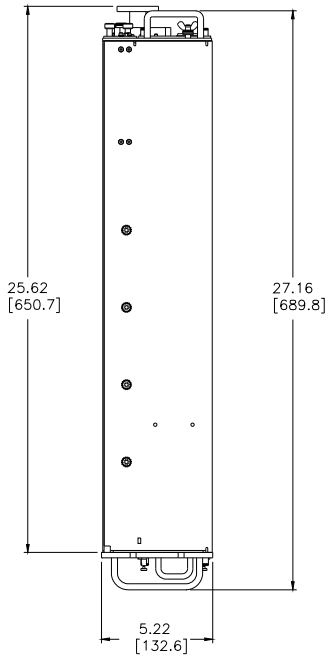
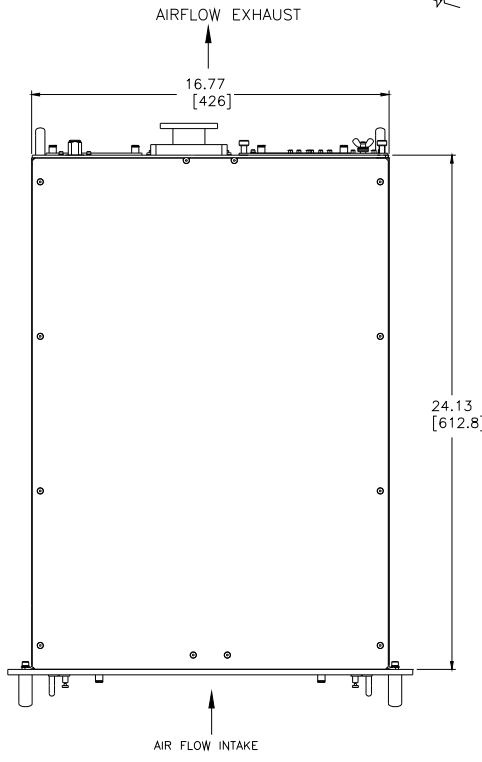

The output waveguide configuration may be rotated by 90° to conform to your system's polarity.

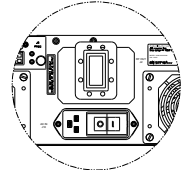

OPTIONAL 90° OUTPUT W/G

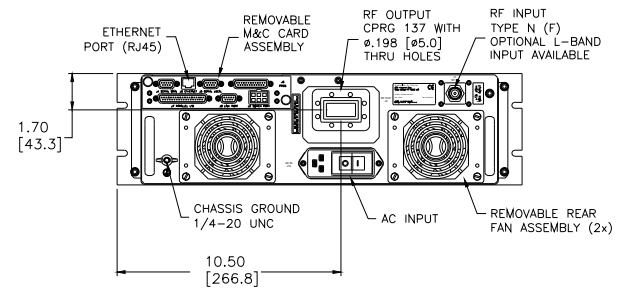
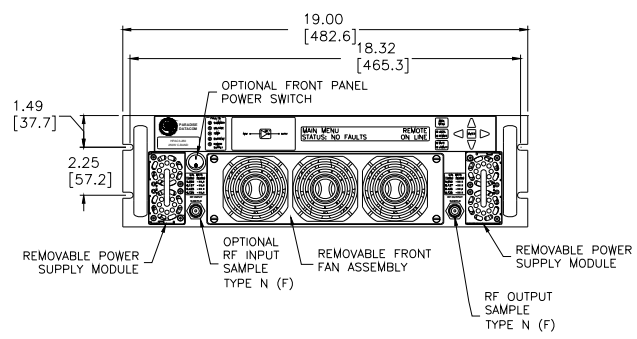

Outline Drawing, 250W C-Band 3RU SSPA Chassis

Redundant Power Supply Option



The combination of a separate +12 VDC output, fully redundant power supply is an excellent means of obtaining the ultimate system reliability.

The power supply is an N+1 redundant configuration meaning that there is one more power supply module available than is required to operate the SSPA. A failure of one power supply module will not take the amplifier off-the-air.

In addition, the power supply modules are removable from the front panel while in operation. There is never a need to remove the power supply chassis from the equipment rack.

Weighing only 9 lbs. (4 kg.) and only 1 rack unit of cabinet space, the redundant power supply chassis is an excellent companion to the SSPA chassis.

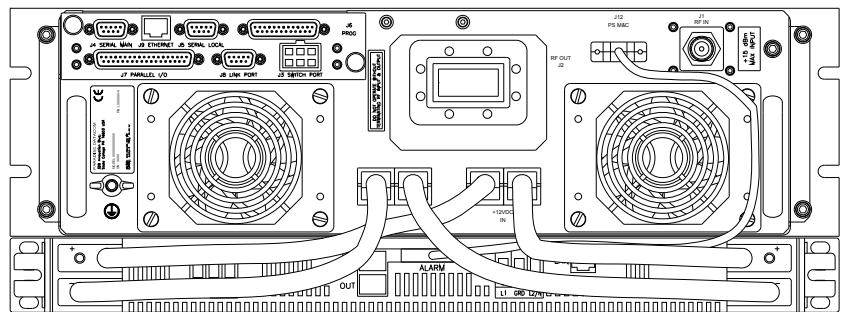

The power supply has a single phase, universal AC input rating from 90-265 VAC, 46-63 Hz. It is power factor corrected to 0.99. Depending on the power requirements of the SSPA, the power supply is configured with two, three or four 1200W hot-swappable modules, each of which weighs 5 lbs. (2.3 kg).

Indoor Rack Mount GaAs Solid State Power Amplifier 3RU Rack Height

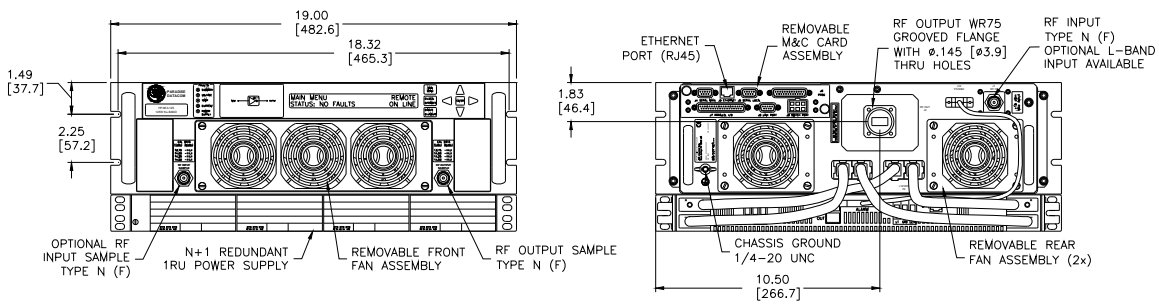
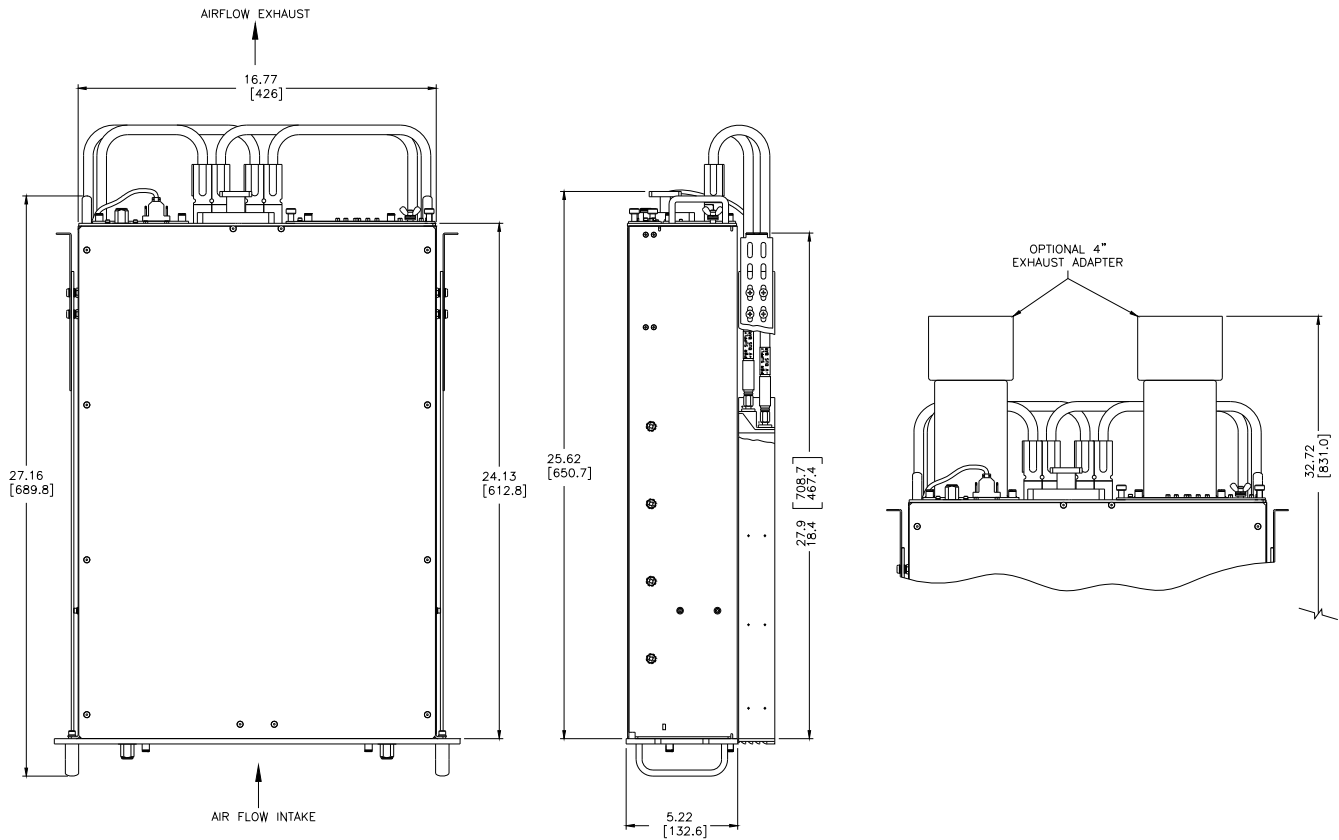

Outline Drawing, 125W Ku-Band 3RU SSPA Chassis with 1RU N+1 Power Supply

Part Number Configuration

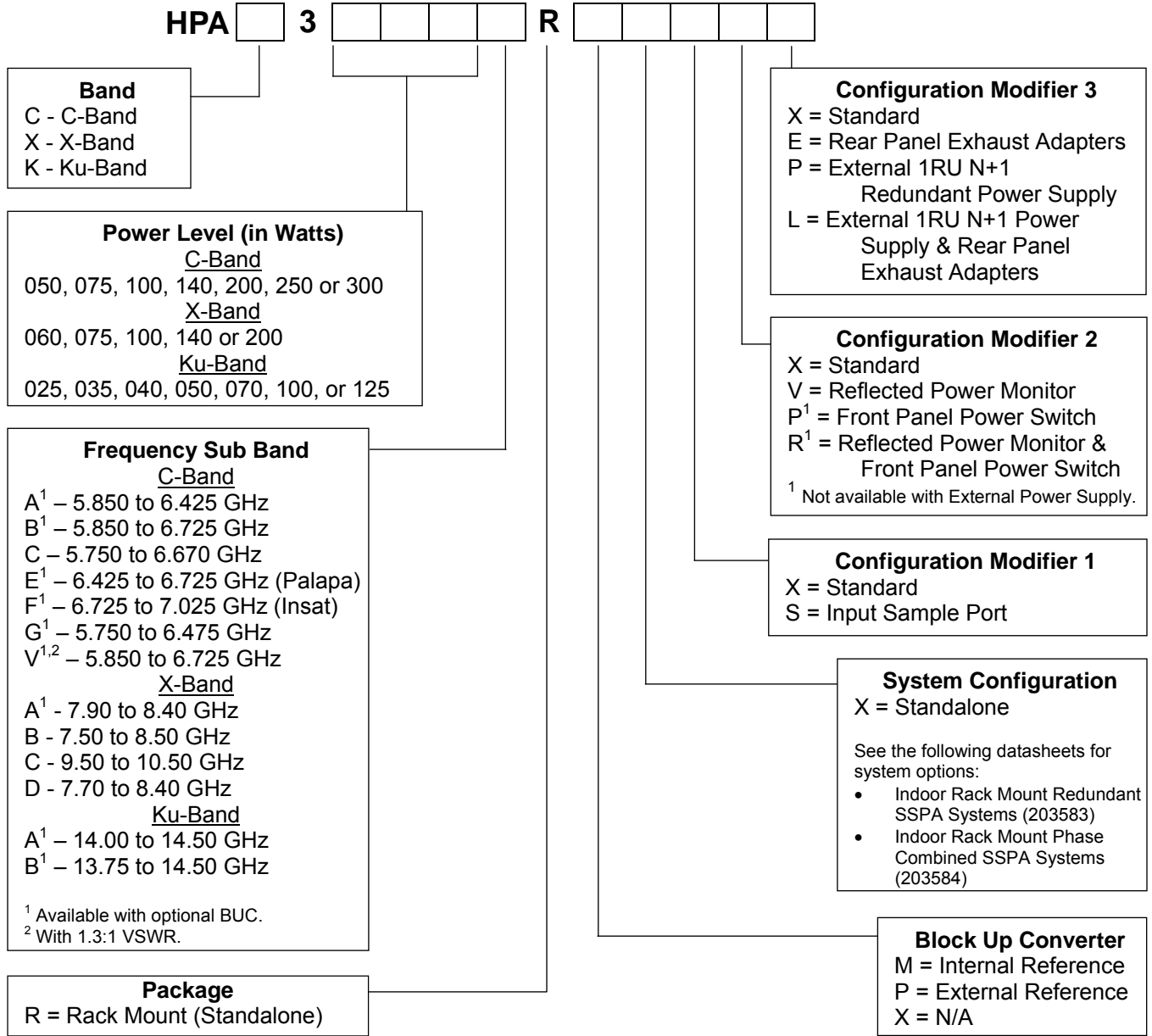

Use and Disclosure of Data

The information contained herein is classified as EAR99 under the U.S. Export Administration Regulations. Export, re-export or diversion contrary to U.S. law is prohibited.

Specifications are subject to change without notice.