



The system has been installed and in operation in major airports throughout the world.

L-band Air Traffic Control Radar Antenna System

The ASC Signal L-band Radar Antenna and Pedestal System is a well-proven off-the-shelf design. The system has been installed and in operation in major airports throughout the world.

The antennas and pedestals are manufactured in accordance with ISO9001 Quality Assurance to stringent specifications and perform to the exacting standards demanded of them. ASC Signal has invested in extensive manufacturing tooling to ensure repeatability in production.

The ASC Signal Corporation L-band Primary Surveillance Radar Antenna System is a widely deployed advanced antenna and pedestal with a proven record of performance and reliability. Drawing on its renowned advanced antenna and pedestal design, ASC Signal fabricates these surveillance radar antenna systems with proven performance advantages. Choose the ASC Signal Advantage for your next Radar System. Complete system solution with rotary joint, control unit and ancillary equipment are also available.

Antenna Features

- High gain
- High and low radiating beams
- Low sidelobes
- Enhanced high angle performance
- Instantaneous polarization switching
- Weather channel



Pedestal Features

- Type tested for operation in extreme environment
- Developed from FAA approved base design
- Versatile and rugged
- Dual helical gearbox
- Selectable rotation speed
- Optional control unit and rotary joint

SPECIFICATIONS

L-band Air Traffic Control Radar Antenna System

Electrical Performance

Frequency Band	1.25 – 1.35 GHz
Low Beam	
Gain	36 dBi min
VSWR	1:1.35
Isolation	20 dB min
Polarizer	Switchable circular/linear
ICR	20 dB
Beamwidth	
Az	1.2°
El	3.8°
Radiation Pattern	
Az	26 dB max, typ. 29 dB
El	Modified Cosecant Sq.
High Beam	
Gain	33 dBi min
VSWR	1:1.55
Polarizer	Switchable circular/linear
ICR	19 dB
Beamwidth	
Az	1.25°
El	5.5°
Radiation Pattern	
Az	26 dB max
El	Modified Cosecant Sq.

Mechanical Performance

Feed Type	Prime focus offset feed system
Reflector Type	Modified Parabola, Aluminum Construction
Tilt Range	-7° to +9°
Weight, net	2,598 kg
Dimensions (l x w x h)	9.3 m x 13 m x 6.7 m

Pedestal Performance

Dual Drive Motors, HP	5
Rotation Rate, rpm	4, 5, 6, 7.5, 10, 12, 15
Peak Torque, ft-lb (dual drive)	4,200
Motor Frequency, Hz	50/60
Motor Voltage, volts	208/380/415
Weight, net	2727 kg
Dimensions (l x w x h)	1.9 m x 1.7 m x 1.7 m

Environmental (Antenna and Pedestal)

Operating	50°C to +50°C
Non-operating	-50°C to +65°C
Radiation Pattern	26 dB max
Humidity	up to 98% at 40°C
Operation	in a radome

Available Options

Rotary Joint
Ladder Kit

Shipping Information

Antenna	
Weight, gross	5010 kg
Dimensions (l x w x h)	
8 skids (each)	6.7 m x 2.3 m x 2.3 m
1 skid	3.1 m x 2.3 m x 1.5 m
1 crate	2.6 m x 1.8 m x 2.0 m
Transportable via five closed ISO containers	

Pedestal	
Weight, gross	3182 kg
Dimensions (l x w x h)	2.2 m x 2.1 m x 1.6 m
Transportable in a single closed ISO container.	

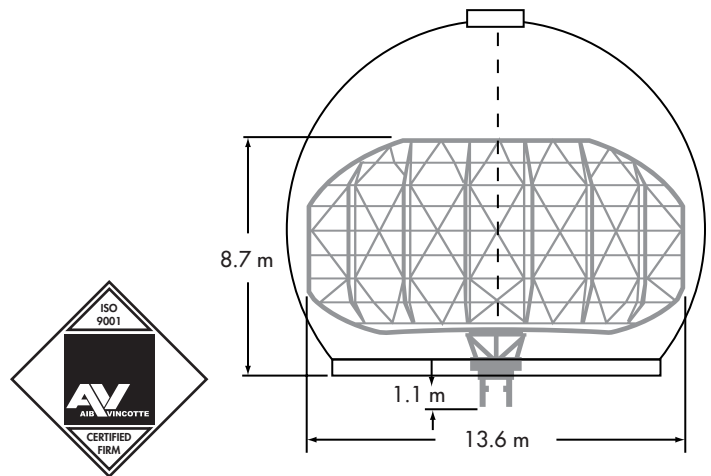

Call today for pricing and interface details for your application. ASC Signal also supplies custom design, system integration, field installation, and test services.



ASC Signal Corporation

www.ascsignal.com

Internet:

All designs, specifications and availabilities of products and services presented in this bulletin are subject to change without notice.