



HP8-59

2.4 m | 8 ft High Performance Parabolic Shielded Antenna, single-polarized, 5.925 -6.425 GHz

Product Classification

Product Type Microwave antenna

General Specifications

Antenna Type HP - High Performance Parabolic Shielded Antenna, single-polarized
Diameter, nominal 2.4 m | 8 ft
Polarization Single

Electrical Specifications

Beamwidth, Horizontal 1.4 °
Beamwidth, Vertical 1.4 °
Cross Polarization Discrimination (XPD) 30 dB
Electrical Compliance ETSI Class 2 | US FCC Part 101A | US FCC Part 74A
Front-to-Back Ratio 66 dB
Gain, Low Band 41.1 dBi
Gain, Mid Band 41.5 dBi
Gain, Top Band 41.9 dBi
Operating Frequency Band 5.925 – 6.425 GHz
Radiation Pattern Envelope Reference (RPE) 2670F
Return Loss 30.7 dB
VSWR 1.06

Mechanical Specifications

Fine Azimuth Adjustment ±5°
Fine Elevation Adjustment ±5°
Mounting Pipe Diameter 115 mm | 4.5 in
Net Weight 227 kg | 500 lb
Side Struts, Included 1 inboard | 1 outboard
Side Struts, Optional 2 outboard
Wind Velocity Operational 110 km/h | 68 mph
Wind Velocity Survival Rating 200 km/h | 125 mph

Wind Forces At Wind Velocity Survival Rating

Angle α for MT Max -110 °

HP8-59

Axial Force (FA)	11284 N 2537 lbf
Force on Inboard Strut Side	4260 N 958 lbf
Force on Outboard Strut Side	5630 N 1266 lbf
Side Force (FS)	5590 N 1257 lbf
Twisting Moment (MT)	-4901 N•m
Weight with 1/2 in (12 mm) Radial Ice	454 kg 1001 lb
Zcg with 1/2 in (12 mm) Radial Ice	729 mm 29 in
Zcg without Ice	673 mm 26 in

HP8-59

Wind Forces At Wind Velocity Survival Rating Image

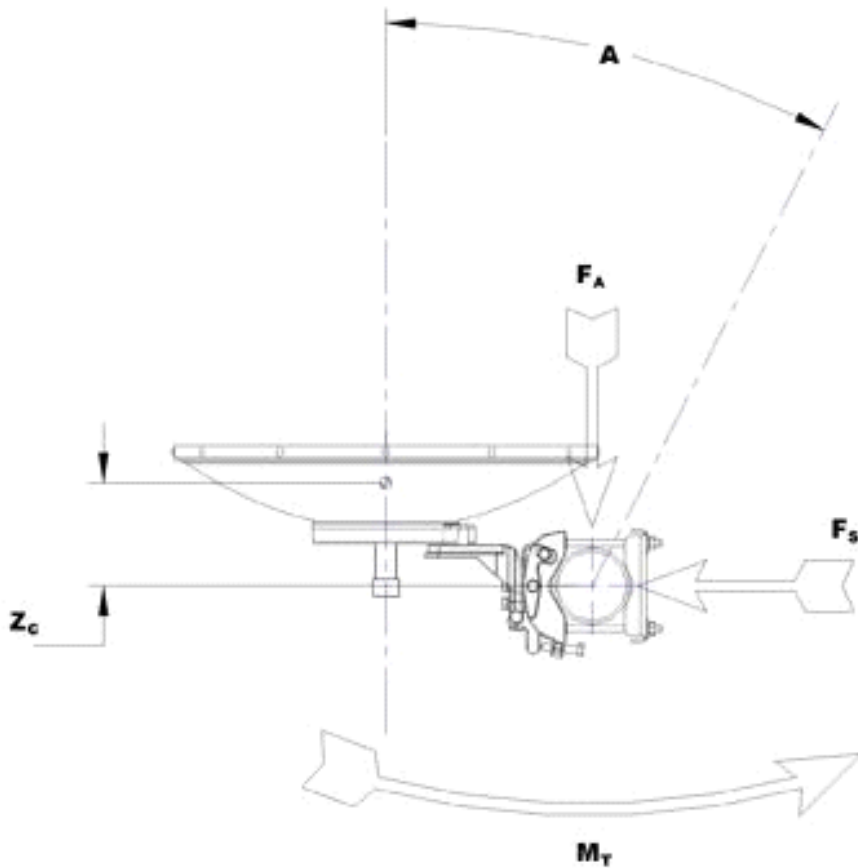

Antenna Dimensions And Mounting Information

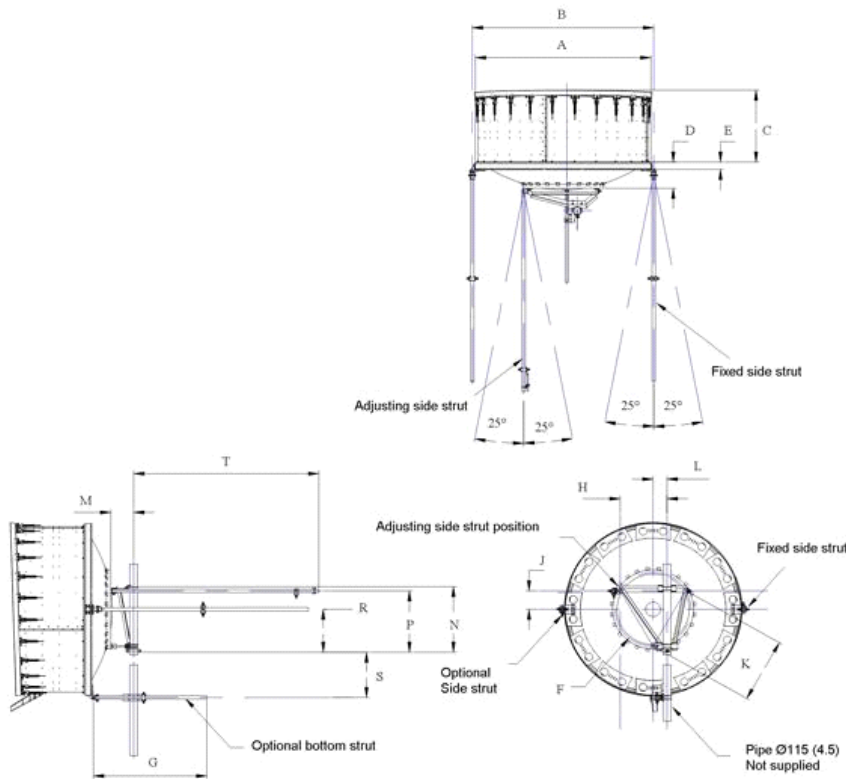

ANTENNA DIMENSIONS			
All dimensions in mm (inches)			
A	2555 (100.5)	K	950 (37.5)
B	2705 (106.5)	L	200 (8)
C	1060 (41.75)	M	330 (13)
D	395 (15.5)	N	950 (37.5)
E	125 (5.0)	P	895 (35.25)
F	1100 (43.25)	R	625 (24.5)
G	1525 (60)	S	695 (27.25)
H	680 (26.75)	T	3050 (120)
J	275 (10.75)		

* Footnotes

Axial Force (FA)

Maximum forces exerted on a supporting structure as a result of wind from the most critical direction for this parameter. The individual maximums specified may not occur simultaneously. All forces are referenced to the mounting pipe.

Cross Polarization Discrimination (XPD)

The difference between the peak of the co-polarized main beam and the maximum cross-polarized signal over an angle twice the 3 dB beamwidth of the co-polarized main beam.

Front-to-Back Ratio

Denotes highest radiation relative to the main beam, at $180^\circ \pm 40^\circ$, across the band. Production antennas do not exceed rated values by more than 2 dB unless stated otherwise.

HP8-59

Gain, Mid Band	For a given frequency band, gain is primarily a function of antenna size. The gain of Andrew antennas is determined by either gain by comparison or by computer integration of the measured antenna patterns.
Operating Frequency Band	Bands correspond with CCIR recommendations or common allocations used throughout the world. Other ranges can be accommodated on special order.
Radiation Pattern Envelope Reference (RPE)	Radiation patterns define an antenna's ability to discriminate against unwanted signals. Under still dry conditions, production antennas will not have any peak exceeding the current RPE by more than 3dB, maintaining an angular accuracy of +/-1° throughout
Return Loss	The figure that indicates the proportion of radio waves incident upon the antenna that are rejected as a ratio of those that are accepted.
Side Force (FS)	Maximum side force exerted on the mounting pipe as a result of wind from the most critical direction for this parameter. The individual maximums specified may not occur simultaneously. All forces are referenced to the mounting pipe.
Twisting Moment (MT)	Maximum forces exerted on a supporting structure as a result of wind from the most critical direction for this parameter. The individual maximums specified may not occur simultaneously. All forces are referenced to the mounting pipe.
VSWR	Maximum; is the guaranteed Peak Voltage-Standing-Wave-Ratio within the operating band.
Wind Velocity Operational	The wind speed where the antenna deflection is equal to or less than 0.1 degrees. In the case of ValuLine antennas, it is defined as a maximum deflection of 0.3 x the 3 dB beam width of the antenna.
Wind Velocity Survival Rating	The maximum wind speed the antenna, including mounts and radomes, where applicable, will withstand without permanent deformation. Realignment may be required. This wind speed is applicable to antenna with the specified amount of radial ice.