

SPECIFICATIONS

FREQUENCY BAND : 10.70 - 12.75 GHz

PASSBAND LOSS : 0.15 dB MAX @ 10.70 - 12.75 GHz
0.10 dB MAX @ 10.95 - 11.70 GHz

PASSBAND VSWR : 1.15:1 MAX

REJECTION : 60 dB MIN @ 13.75 to 14.50 GHz

PRESSURIZATION : SEALED TO 5 PSIG

FINISH
FLANGE FACES : ZINC-NICKEL PLATED
(PER AMS 2417G, TYPE II, CLASS 2)

EXTERIOR :
WHITE PAINT, COLOR No 17875
PER FED-STD-595

REVISIONS

ZONE	REV.	DESCRIPTION	DATE	APPROVED
A	A	SEE REVISION RECORD	10-10-05	
B	B	SEE EC 13015, make EF MFG package	3/27/2014	
C	C	SEE EC 13056	6/12/2014	

WR75
FLANGE INTERFACE
BOTH ENDS

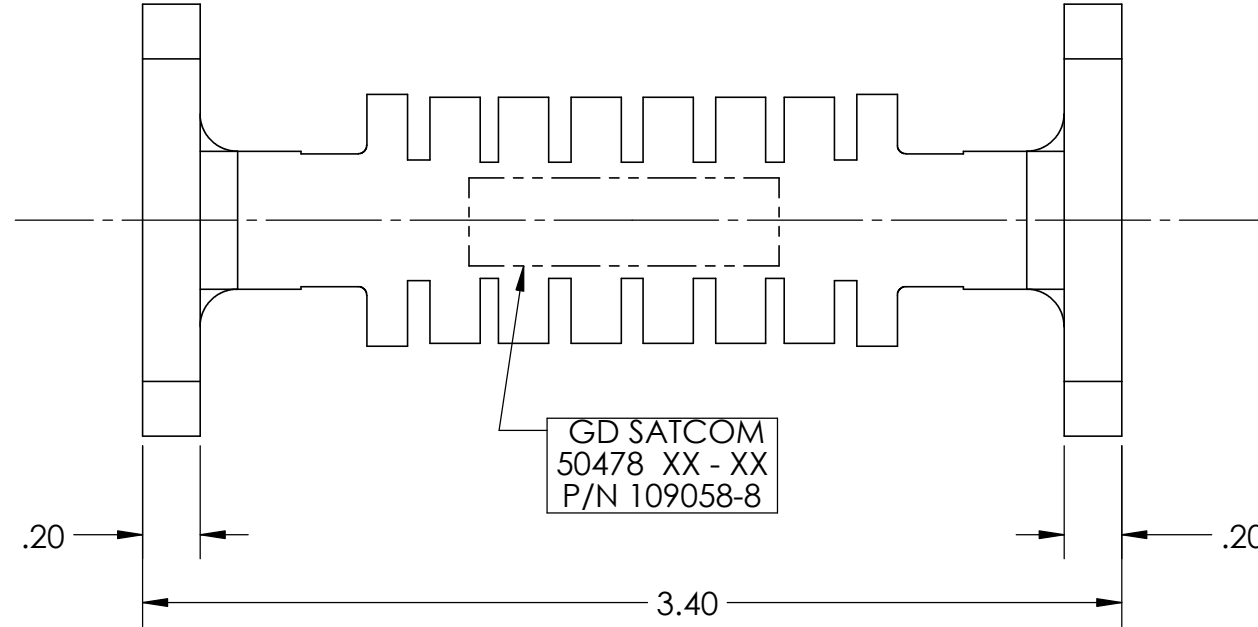
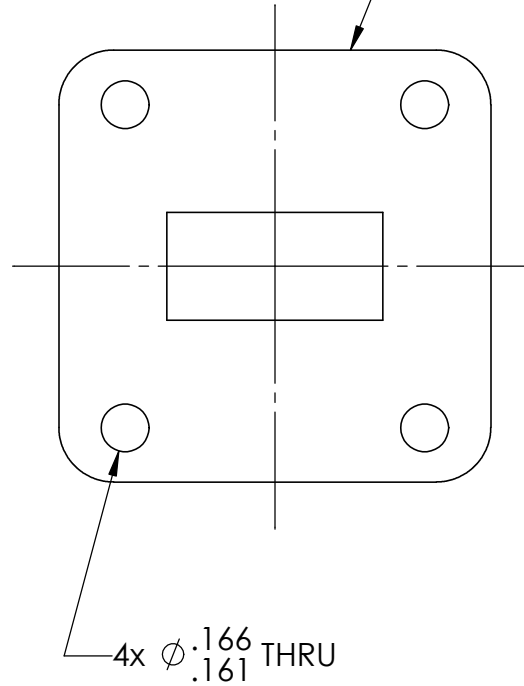

O-RING GROOVE
1.31 OD
1.11 ID
↓ .050

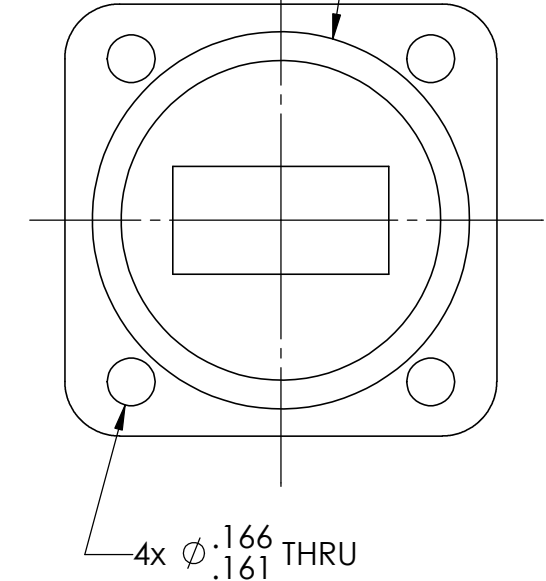

NOTES: UNLESS OTHERWISE SPECIFIED.

DO NOT SCALE DRAWINGS		APPROVALS	DATE	GENERAL DYNAMICS PROPRIETARY		
<small>UNLESS OTHERWISE SPECIFIED, INTERPRET DIMENSIONING & TOLERANCING PER ANSI/ASME Y14.5M-2009. DIMENSIONS ARE IN INCHES. DIMENSIONS SHOWN IN () ARE FOR REFERENCE ONLY.</small> TOLERANCES: TWO PLACE DECIMAL ± .01 THREE PLACE DECIMAL ± .002 FOUR PLACE DECIMAL ± .0010 ANGLES ± 0°30'		DRAWN: TOVALIN	10-21-98	GENERAL DYNAMICS SATCOM Technologies 3111 Fujita Street, Torrance CA 90505, (310) 539-6704 TITLE: <h3 style="text-align: center;">Ku-BAND FILTER 10.70 - 12.75 GHz</h3>		
		CHECKED:				
		RF DESIGN:				
		MFG:				
<small>THIRD ANGLE PROJECTION</small> 		QA:		SIZE	CAGE CODE	
		ENG MGR:		B	50478	
<small>EAR CONTROLLED</small> Export or re-export subject to 15 CFR 700 - 799		PROJECT:		DWG No.	REV	
		MATERIAL		109058-8	C	
				SCALE: 3:2	WEIGHT: LB	SHEET 1 of 3