



HSX15-44-D4M

Fine Azimuth Adjustment	±5°
Fine Elevation Adjustment	±3.6°
Mounting Pipe Diameter	115 mm   4.5 in
Net Weight	499 kg   1100 lb
Side Struts, Included	1 inboard
Side Struts, Optional	2 outboard
Wind Velocity Operational	110 km/h   68 mph
Wind Velocity Survival Rating	200 km/h   125 mph

## Wind Forces At Wind Velocity Survival Rating

Angle $\alpha$ for MT Max	110 °
Axial Force (FA)	39672 N   8919 lbf
Force on Inboard Strut Side	35233 N   7921 lbf
Side Force (FS)	19652 N   4418 lbf
Twisting Moment (MT)	29828 N•m
Weight with 1/2 in (12 mm) Radial Ice	952 kg   2099 lb
Zcg with 1/2 in (12 mm) Radial Ice	1372 mm   54 in
Zcg without Ice	1306 mm   51 in

HSX15-44-D4M

## Wind Forces At Wind Velocity Survival Rating Image

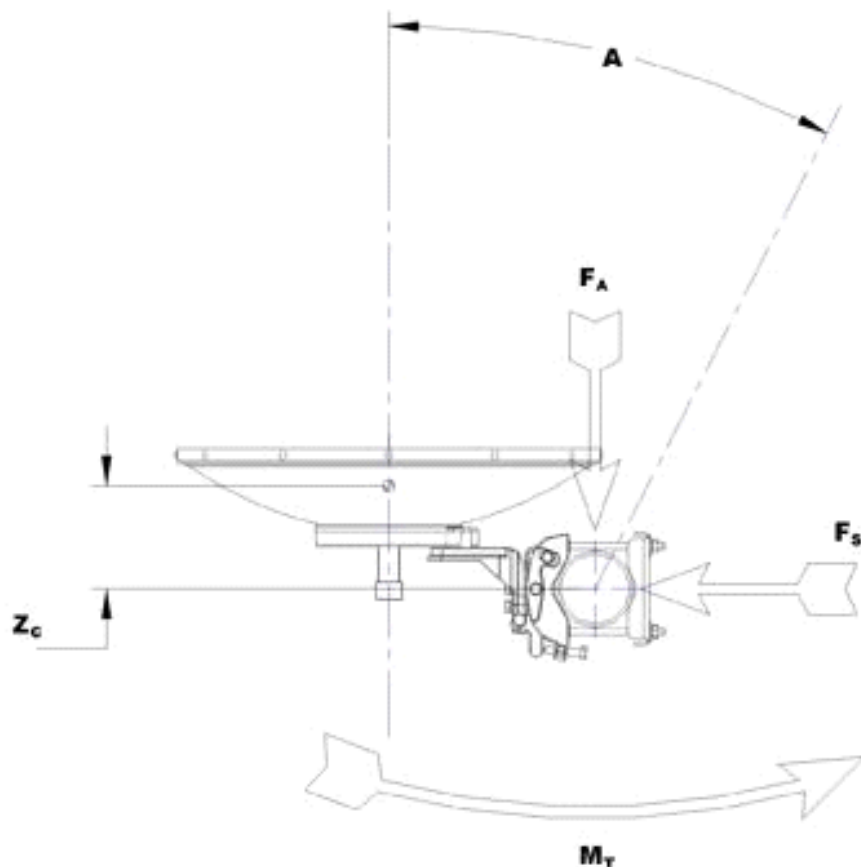

## Packed Dimensions

Gross Weight, Packed Antenna	1136.0 kg		2504.5 lb
Height	2570.0 mm		101.2 in
Length	4930.0 mm		194.1 in
Volume	19.4 m <sup>3</sup>		
Width	1530.0 mm		60.2 in

HSX15-44-D4M

## Antenna Dimensions And Mounting Information

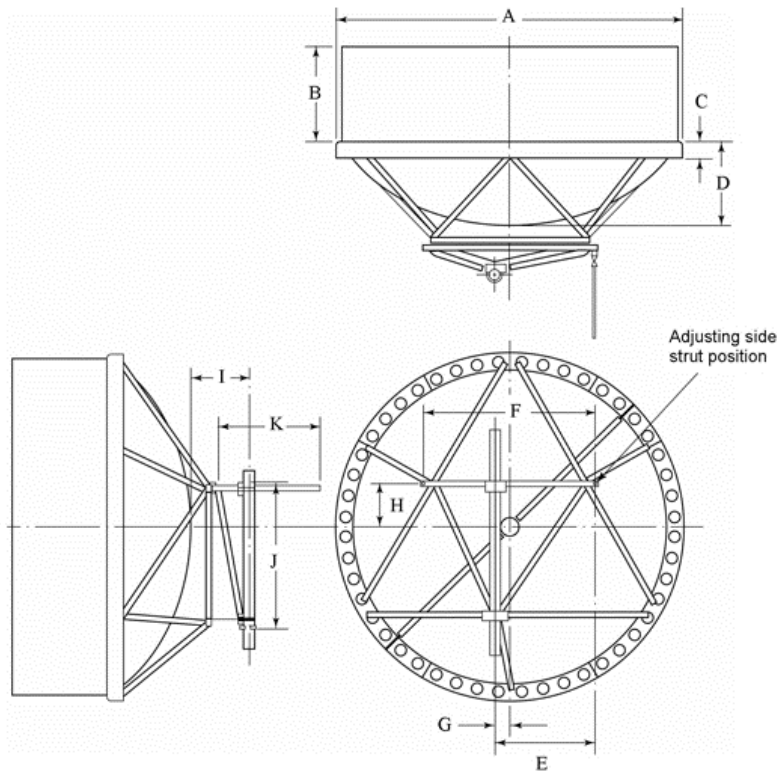

ANTENNA DIMENSIONS			
All dimensions in mm (inches)			
A	4685 (184.5)	G	200 (8)
B	1245 (49.0)	H	595 (23.5)
C	135 (5.3)	I	595 (23.5)
D	865 (34.0)	J	1930 (76.0)
E	1310 (51.5)	K	1240 (108)
F	2210 (87)		

## Regulatory Compliance/Certifications

Agency	Classification
ISO 9001:2008	Designed, manufactured and/or distributed under this quality management system

### \* Footnotes

Axial Force (FA)	Maximum forces exerted on a supporting structure as a result of wind from the most critical direction for this parameter. The individual maximums specified may not occur simultaneously. All forces are referenced to the mounting pipe.
Cross Polarization Discrimination (XPD)	The difference between the peak of the co-polarized main beam and the maximum cross-polarized signal over an angle twice the 3 dB beamwidth of the co-polarized main beam.
Front-to-Back Ratio	Denotes highest radiation relative to the main beam, at $180^\circ \pm 40^\circ$ , across the band. Production antennas do not exceed rated values by more than 2 dB unless stated otherwise.

HSX15-44-D4M

Gain, Mid Band	For a given frequency band, gain is primarily a function of antenna size. The gain of Andrew antennas is determined by either gain by comparison or by computer integration of the measured antenna patterns.
Operating Frequency Band	Bands correspond with CCIR recommendations or common allocations used throughout the world. Other ranges can be accommodated on special order.
Packing	Andrew standard packing is suitable for export. Antennas are shipped as standard in totally recyclable cardboard or wire-bound crates (dependent on product). For your convenience, Andrew offers heavy duty export packing options.
Radiation Pattern Envelope Reference (RPE)	Radiation patterns define an antenna's ability to discriminate against unwanted signals. Under still dry conditions, production antennas will not have any peak exceeding the current RPE by more than 3dB, maintaining an angular accuracy of +/-1° throughout
Return Loss	The figure that indicates the proportion of radio waves incident upon the antenna that are rejected as a ratio of those that are accepted.
Side Force (FS)	Maximum side force exerted on the mounting pipe as a result of wind from the most critical direction for this parameter. The individual maximums specified may not occur simultaneously. All forces are referenced to the mounting pipe.
Twisting Moment (MT)	Maximum forces exerted on a supporting structure as a result of wind from the most critical direction for this parameter. The individual maximums specified may not occur simultaneously. All forces are referenced to the mounting pipe.
VSWR	Maximum; is the guaranteed Peak Voltage-Standing-Wave-Ratio within the operating band.
Wind Velocity Operational	The wind speed where the antenna deflection is equal to or less than 0.1 degrees. In the case of ValuLine antennas, it is defined as a maximum deflection of 0.3 x the 3 dB beam width of the antenna.
Wind Velocity Survival Rating	The maximum wind speed the antenna, including mounts and radomes, where applicable, will withstand without permanent deformation. Realignment may be required. This wind speed is applicable to antenna with the specified amount of radial ice.