



# AL-1600 SYSTEMS



## L/S-Band Tracking Solution

AL-1600 series is a self-contained elevation-over-azimuth tracking solution for L/S-band links providing high performance under the most demanding operational conditions. This flexible system may be ground-based, transportable, or shipboard (with additional stabilization) and can serve a wide variety of medium range applications such as, short range aeronautical telemetry and UAV command and control.

The antenna motion system is based on integrated, state-of-the-art, digital servo amplifiers (DSA) providing a simple RS-422 position control and readout interface. The DSA includes all servo loops that control the antenna motion, except for the auto-track loop that is closed via a separate tracking receiver and Antenna Control Unit (Orbit AL-4000). The auto-track function is based on a high-performance E-scan type angle discriminating antenna feed. The AL-1600 series supports different types of antennas, slip rings and rotary joints.

Furthermore, tracking antennas can be provided in a variety of configurations tailored to meet a broad range of field requirements, including: different frequency ranges; various linear and circular polarization combinations; interference rejection filtering; additional uplink (transmit) paths; segmented reflectors to facilitate transportation.

Antenna motion characteristics are fully configurable to include: continuous azimuth rotation utilizing a multi-channel RF rotary-joint and slip-rings; higher torque required under extreme wind conditions; different torque-speed combinations. The antenna system can be adapted both mechanically and electronically to accommodate specific user interface requirements by means of a suitable base riser, and fiber optic or other motion control interfaces. The antenna tracking system can be augmented by adding an acquisition-aid antenna with or without auto-tracking capability as well as a boresight camera that can be utilized as an independent video tracker, functionally integrated with the Orbit AL-4000.

Operational safety is guaranteed by features such as over-current, voltage, and temperature protection, electrical limit switches, and mechanical stops. The system is easy to assemble and dismantle and includes comprehensive BIT (Built-in-Test) abilities for the entire pedestal.

## FEATURING

- Parabolic reflector antenna
- E-scan auto-track feed
- Integrated LNAs & filters
- EL over AZ axes configuration (optional stabilization)
- Digital servo drive
- Brushless motor and planetary gear assembly
- High dynamics, high accuracy, low backlash
- Robust, reliable, environmentally durable
- Modular & easily maintainable

*Orbit is a world leading supplier of innovative satellite communications solutions as well as tracking, audio and communications management systems. The company's products are deployed on board airborne, marine and ground platforms with both military and commercial customers and are installed on thousands of projects with companies and organizations worldwide.*

*Orbit, a public company, has an international marketing and sales network that includes the United States, Europe, and the Far East in addition to its international technical service centers located around the world.*

Orbit AL-1600 Ku-Band Tracking Antenna System Specification

	AL-1604LS		AL-1606LS	
Parameters	Specification			
Antenna diameter	4.0 ft		6.0 ft	
Frequency	1.435-1.850GHz (L-band), 2.200-2.400GHz (S-band)			
	L	S	L	S
Gain	21.5 dBi	25.5 dBi	23.5 dBi	28.0 dBi
G/T	-1.0 dB/°K	3.0 dB/°K	3.0 dB/°K	7.5 dB/°K
Beamwidth	11.5°	7.6°	7.8°	5.0°
1 <sup>st</sup> Sidelobe	-16 dB		-17 dB	
Wind				
- Operational	50 mph		40 mph	
- Stowed	60 mph		60 mph	
Weight, max. (without base riser)	463 lbs		485 lbs	

Note: Unless otherwise indicated, all specifications are typical at mid-band frequency.

All Models			
Parameters	Specification	Parameters	Specification
Azimuth:	±200° ≤20°/sec ≤20°/sec <sup>2</sup>	Elevation:	-5° to +185° ≤20°/sec ≤20°/sec <sup>2</sup>
- Travel		- Travel	
- Velocity		- Velocity	
- Acceleration		- Acceleration	
Power requirement	470 VA	Temperature	-13°F to 140°F
Humidity	95%	Rain	4 inch/hr

General View of AL-1600 Pedestal & System

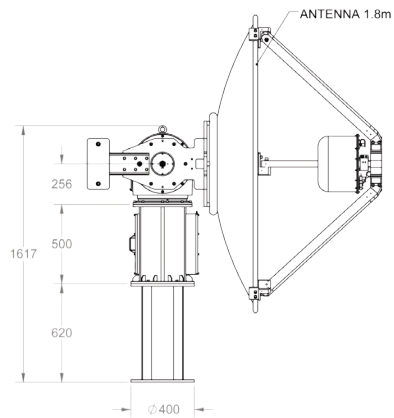

\* Orbit reserves the right to change this specification without notice



SatelliteDish.com 954-941-8883