

7.6 Meter ESA

Like all ASC Signal earth station antennas, the 7.6 Meter Earth Station Antenna provides high gain and exceptional pattern characteristics.

This antenna system is designed to address the stringent requirements of both the television broadcast industry and telecommunications network operators who demand unsurpassed flexibility and electrical performance in high-quality, cost-effective, and reliable packages.

The 7.6 M is capable of operation at C-, X-, Ku- and K- bands with the selection of feed and combiner systems.

The versatile tripod mount, features 180° azimuth coverage in three contiguous 120° overlapping ranges, and 85° continuous elevation adjustment. This large range of adjustment provides non-critical foundation orientation, and the ability to view geostationary satellites, from horizon-to-horizon, from any location worldwide.

The electrical performance and exceptional versatility provides the ability to configure the antenna with your choice of combining network. That versatility is provided at the time of initial purchase, as well as in the future, as your satellite communication requirements evolve.

This antenna system is used worldwide in broadcast applications and high density data, voice and communications networks. The ASC Signal 7.6 meter earth station antenna features a computer-optimized dual reflector Gregorian optics system and close-tolerance manufacturing techniques.

This combination provides extremely accurate surface contour resulting in exceptionally high gain and closely controlled pattern characteristics. ASC Signal earth station antennas provide maximum durability with minimal maintenance.



Features

- Rugged aluminum and steel construction
- Superior Pointing Accuracy
- A computer-optimized dual reflector Gregorian system
- Deep Equipment Enclosure
- 3 year warranty on all structural components
- ITU-R S.580 and S-465
- U.S. FCC Regulation 25.209
- Russian Homologation Certificate # OC/1-AO-136
- Intelsat E-3, F-3

7.6 Meter ESA

EARTH STATION ANTENNA

Design Standards

Reflector	Aluminum painted with highly diffusive white paint
Ground Mount	Hot-dipped galvanized steel, per ASTM-A123 for structural steel.
Hardware	Sizes ≤ 3/8 in (9.5mm), stainless steel, passivated per MIL-F-14072-E300 Sizes ≥ 3/8 in (9.5mm), hot-dipped galvanized stainless steel, passivated per ASTM-A123

Environmental Performances

Operating Temperature	-40° to 52°C (-40° to 125°F)
Seismic (Earthquake)	1 G Vertical and Horizontal acceleration. Equivalent to a Richter Magnitude 8.3, and Grade 11 on the modified Mercalli Scale
Rain	4 in (102 mm) per hour
Solar Radiation	360 BTU/hr/ft ² (1135 Watts/m ²)
Relative Humidity	100%
Shock and Vibration	As encountered by commercial Air, Rail and Truck shipment.
Atmospheric Conditions	As encountered by Moderately Corrosive Coastal and Industrial Areas.
Survival Winds	125mph (200km/h) in any position of operation
Operational Winds	45mph (72km/h) Gusting to 65mph (105km/h)

Mechanical Performances

The 7.6m Antenna mechanical general specifications and performances are listed in below table. Additional information, dimensions and layout may be provided by ASC Signal on a case-by-case basis.

Optics Type	Dual Reflector Gregorian
Reflector Material	Precision-Formed Aluminum
Reflector Segments	16
Mount Type	Az over El, Tripod mount

Antenna Pointing Range, Coarse/(Continuous)

Elevation:	5-90° (85°)
Azimuth:	180° (120°)
Polarization	180° (180°)

Hub/Enclosure Dimensions

Diameter	52 in. (1.32 m)
Depth	46 in. (1.17 m)

Shipping Information

Packing Options

Standard Commercial Domestic Pack	Included
Ocean Export Pack - For non-containerized, packed for seal against salt water spray	OCEANSHP-LG
Air Export Pack - For freighter aircraft shipments. Lower deck AirPack requires specialized bids	AIR EXPORT PACK-LG
Container Packaging	CNTPCK-LG

Required Shipping Container

Standard 40 ft land/sea container	Quantity 1
-----------------------------------	------------

Shipping container information is given for basic configuration and may vary depending on the selected options, please contact ASC Signal for specific container loading plan.

7.6 Meter ESA

Dimensional Drawings

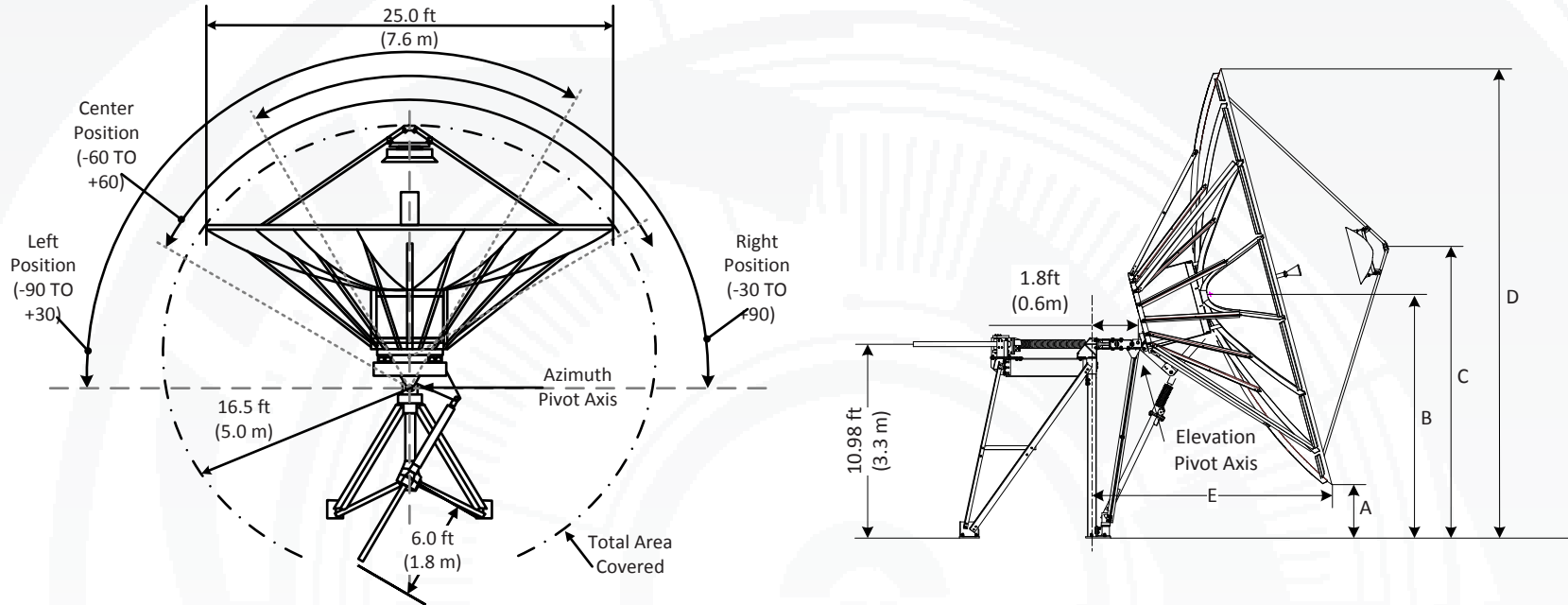

Top View

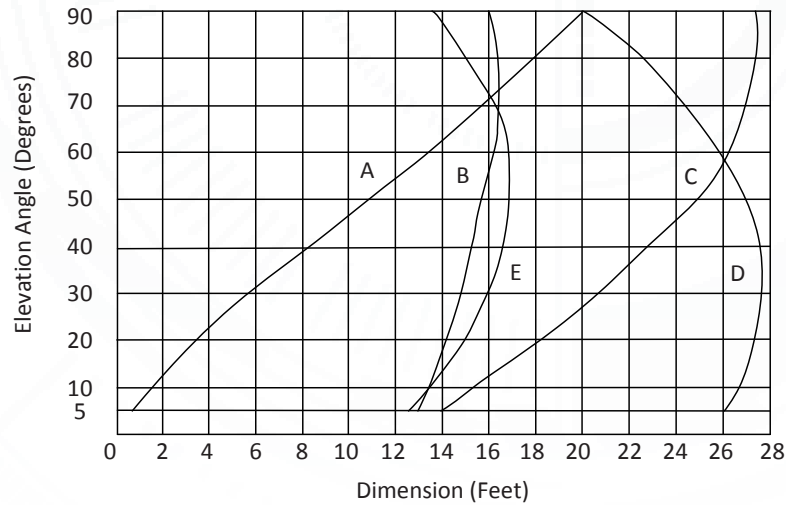

EARTH STATION ANTENNA

7.6 Meter ESA

EARTH STATION ANTENNA

Motor Drive Speed Summary

	Variable	
Azimuth	0.05°/s	0.5°/s
Elevation	0.05°/s	0.5°/s
Polarization	1°/s	

Motorization

One motorization system is available for this antenna: the NGC tracking system that can support Steptrack, Smartrack and Ephemeris orbital tracking.

Motor Kit

Azimuth/Elevation Motor Kit	NGC-MK7
-----------------------------	---------

Polarization Drive Kit (DC Step Motors)

Standard Temperature (> -20°C)	NGC-PK9DRA
Low Temperature operation (< -20°C)	NGC-PK9DRA-LO

Outdoor Unit Controller

Power 200 - 230 VAC, 3 Phase 50/60 Hz	NGC-ODU-208-5
Power 380 - 460 VAC, 3 Phase 50/60 Hz	NGC-ODU-380-5

Antenna Configurations

Ku, K-band Eutelsat Compliant Earth Station Antennas

Motorizable Mount with Az/EI Jackscrews.	ES76E-1
--	---------

C, X, Ku, K-band Earth Station Antennas

Motorizable Mount with Az/EI Jackscrews.	ES76K-1
--	---------

Antenna controller, motorization and options are detailed in specific bulletins, please contact ASC Signal..

Motorization and NGC Options

Indoor	
NGC-IDU	NGC Rack Mounted Antenna Controller W/LCD Touch Panel
NGC-001	NGC-IDU Analog Telephone Modem
NGC-002	NGC-IDU Spectrum Analyzer Card, Analog
NGC-003	NGC-IDU DVB Receiver Card
NGC-RTX-2	NGC IDU, L-Band Internal Beacon Receiver
NGC-006	NGC-IDU Emergency Stop Button
NGC-007	NGC-IDU 10 Mhz Reference Source
NGC-008	NGC-IDU Redundant Power Supply
NGC-009	NGC-IDU Rack Slides
NGC-101	NGC-IDU Step Tracking Software
NGC-102	NGC-IDU Smartrack Software
NGC-103	NGC-IDU Predictive Track Software
NGC-104	NGC-IDU Full Tracking Capability Software
NGC-106	NGC-IDU Remote Access Software Package
NGC-107	NGC-IDU Spectrum Analyzer Enhanced User Interface
NGC-108	Receive Pattern Test Tool
NGC-109	Redundancy Control Software
NGC-111	Sand/Dust Deviator Feature
NGC-115	Uplink Power Control Software Function
NGC-ULPC-INTFC	Uplink Power Control System Single Channel
NGC-ULPC-INTFC-2	Uplink Power Control System Dual Channel
NGC-119	NGC High Availability System Redundancy Software
Outdoor	
NGC-201	NGC ODU Low Temperature Kit (-40 C)
NGC-202	NGC ODU High Temperature Kit (+60 C)
NGC-205	NGC ODU AC Polarization Drive Interface
NGC-206	NGC Exterior Emergency Stop Button
NGC-207	Pre Movement Alert Warning Light And Annunciator
NGC-211	Dual Path NGC Redundancy
NGC-AESC	Environmental System Controller
RED11-x	Hub Mounted 1:1 LNA/LNB Redundancy Plate
RED12-x	Hub Mounted 1:2 LNA/LNB Redundancy Plate

Antenna controller, motorization and options are detailed in specific bulletins, please contact ASC Signal.

7.6 Meter ESA

Feed Matrix

C- BAND FEED SYSTEMS	PORT	CO	CP	LP	RX 3.625 - 4.2 GHz	RX 3.4 - 4.2 GHz	RX 4.5 - 4.8 GHz	TX 5.850 - 6.425 GHz	TX 5.850 - 6.725 GHz	TX 5.725 - 6.725 GHz	TX 6.725 - 7.025 GHz
2CLPNC-76	2	X		X	X			X	X		
2CPNC-76-109	2		X		X			X			
2CPNCR-76-109	2		X		X						
2CPWC-76	2		X			X		X	X		
2CPWCR-76-120	2		X			X					
2CPWWC-76	2		X			X				X	
2LPNC-76	2			X	X			X			
2LPNCR-76	2			X	X						
2LPUC-76	2			X			X				X
2LPWC-76	2			X		X		X			
2LPWWC-76	2			X		X				X	
2LPWCR-76	2			X		X					
4CPNC-76-206	4		X		X			X			
4LPNC-76	4			X	X			X			
4LPWWC-76	4			X		X				X	
4CPWWC-76	4		X			X				X	

X- BAND FEED SYSTEMS	PORT	CP	LOW PIM	RX 7.25 - 7.75 GHz	TX 7.9 - 8.4 GHz
2CPX-76	2	X		X	X
2CPXF-76	2	X		X	X
4CPX-76	4	X		X	X
2CPXM-76	2	X	X	X	X
4CPXM-76	4	X	X	X	X

For redundant application, LNA support kits are available for each of the above feeds. Please contact ASC Signal.

7.6 Meter ESA

Feed Matrix

KU- BAND FEED SYSTEMS	PORT	CP	LP	RX 10.7 - 12.75 GHz	RX 10.95 - 12.75 GHz	RX 10.7 - 11.7 GHz	TX 13.75 - 14.5 GHz	TX 13.75 - 14.8 GHz	TX 14.0 - 14.5 GHz	TX 12.75-13.25 /13.75 -14.8 GHz	TX 13.0 - 14.5 GHz
2LPKU-76	2		X	X				X			
2LPKUM-76-W	2		X		X				X		
2LPKUR-76-W	2		X		X						
4LPKU-76-1	4		X	X				X			
4LPKU-76-2	4		X			X				X	
4LPKU-76-4	4		X	X							X
4CPKU-76-S6	4	X		X			X				

K- BAND FEED SYSTEMS	PORT	CP	LP	RX 10.7 - 12.75 GHz	TX 17.3 - 18.4 GHz
2LPKK-76	2		X	X	X
4CPKK-76	4	X		X	X
4LPKK-76	4		X	X	X

C/KU- BAND FEED SYSTEMS	PORT	CP	LP	RX 3.4 - 4.2 GHz	RX 10.7 - 12.75 GHz
4LPWCLPKUR-76	4		X	X	X
4CPWCLPKUR-76	4	X	X	X	X
4CPLWCLPKUR-76	4	X	X	X	X

For redundant application, LNA support kits are available for each of the above feeds. Please contact ASC Signal.

7.6 Meter ESA

Antenna Options and Spares

EARTH STATION ANTENNA

Anchor Bolt and Template Kits Options	
201630	Anchor Bolt Kit for 7.6 Meter Earth Station Antennas
206505	Anchor Bolt Template for 7.6 Earth Station Antennas
Heating Options	
FH5A	Ku- and K-Band Feed Heater Kit
FH9A	C-Band Feed Heater Kit
FHXA	X- Band Feed Heater Kit
WEC76R-208-100	Electric Hot Air De-Ice System, 208 VAC, 3 Phase
WEC76R-380-100	Electric Hot Air De-Ice System, 380 VAC, 3 Phase
Hub Equipment Options	
EMRGYLT-115	Emergency Hub Light Kit, 115 VAC
EMRGYLT-230	Emergency Hub Light Kit, 230 VAC
FV5-115	Fan and Vent Kit, 115 VAC
FV5-230	Fan and Vent Kit, 230 VAC
HUBHTR-230	Antenna Hub Heater, 230 VAC
HUBLCNTR-115/240	Hub Power Center, 115/240 VAC
HUBLCNTR-230	Hub Power Center, 230 VAC
HUBLT-115	Hub Light Kit, 115 VAC
HUBLT-230	Hub Light Kit, 230 VAC
Safety Options	
ANTGND-9	Foundation Installed Grounding Kit
LRK9	Lightning Rod Kit
MANPL7	Maintenance Platform and Ladder Kit
OBWRNLT-115	Obstruction Warning Light Kit, 115VAC
OBWRNLT-230	Obstruction Warning Light Kit, 230VAC

Other Options	
201769	Elevation Handwheel Kit (2 required)
201887	Azimuth Handwheel Kit
209906-2	Lubrication and Maintenance Kit
223711-2	Theodolite Alignment Kit (theodolite not incl)
BRNG-7693-C	Guard, Feed Window
BRNG-4676-KU	Guard Feed Window
BRNG-76-K	Guard Feed Window
FTST	Feed System Testing
NPN-LG	Custom Color Painting for Reflector
SPCOL-FEED	Custom Color Painting for Feed
TK-MAN-LG	Tool Kit, Large Manual Antennas
TK-MOT-LG	Tool Kit, Large Motorized Antennas
ANGVERN-7	Manual Angle Indicator
BRNG-374676-X	Guard, Feed Window. X- Band
OM76	OM Manual
202436	C- Band Spare Feed Window
221691	Spare Feed Window, Ku- Band

Azimuth and Elevation Cross Axis Waveguide Options	
XAPC-76	C- Band Cross-Axis kit, for 2 port feeds
XAPC-76-UPG	Upgrade C- Band Cross-Axis kit, 4 port feeds
XAPKU-76	Ku- Band Cross-Axis kit, for 2 port feeds
XAPKU-76-UPG	Upgrade Ku- Band Cross-Axis kit, 4 port feeds
XAPKK-76	K- Band Cross-Axis kit, for 2 port feeds
XAPKK-76-UPG	Upgrade K- Band Cross-Axis kit, 4 port feeds

Environmental Systems Options	
PDKU-208	Precipitation Deviator, Ku, 208 VAC, 3 Phase
PDKU-380	Precipitation Deviator, Ku, 380 VAC, 3 Phase