

# Type 698: 69cm Rx/Tx Extended Ka-Band Antenna

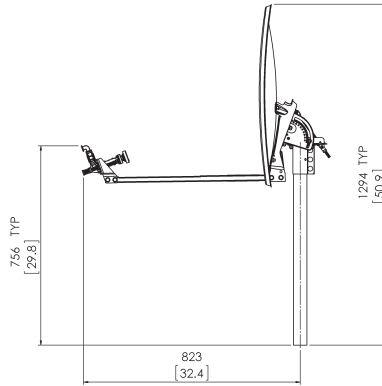

- ISO 9001:2008 CERTIFICATE OF REGISTRATION
- One-piece precision Steel Reflector
- Precision Az/EI Mount
- Fine Azimuth and Elevation Adjustment Features
- All Materials Comply with EU Directive No. 2002/95/EC (RoHS)



- 720 Hour Salt Spray Hardware
- Designed for Skyware Global Ka-Band Feed Components
- Designed for typical Ka-Band electronics.

New Skyware Global 69cm Rx/Tx Extended Ka Band Antenna is a rugged, commercial quality product suitable for the most demanding applications.

- The reflector is constructed from pressed steel for strength and accuracy. A proprietary process developed by Skyware Global ensures high RF reflectivity from powder coated galvanized steel.
- The precision Az/EI mount is made of galvanized steel for excellent corrosion resistance. This mount includes special features to increase pointing accuracy with low backlash and lockdown error.
- This Az/EI allows the antenna to be installed on standard 2" or 2 3/8" OD installation mounts.
- All hardware is plated to 720 hour salt spray standards tested in accordance with ASTM B-117.
- Tx Cross-Polarization Isolation of 25dB (within 1dB b/w) or better for CP Application.
- Excellent Tx Port to Port Isolation of 90dB or better.
- Meets or exceeds regulatory agency requirements .
- System designed for typical Ka-Band RF Electronics.



Satcom solutions for the long haul

<http://www.SatelliteDish.com> 954-941-8883

REV 03/15-01  
Page 1 of 2

• PRODUCT SPECIFICATIONS

**RF Performance**

Operating Frequency	
RX .....	.18.3-20.2GHz
TX .....	.28.3-30.0GHz
Midband Gain (+/.5db)	
RX .....	.41.4 dBi @ 20.2Ghz
TX .....	.44.9 dBi @ 30.0Ghz
VSWR .....	1.3:1 Max
3 dB Beamwidth	
TX .....	.1.1°
RX .....	.1.7°
Sidelobe Envelope Co-Pol (dBi)	
100 λ/D < θ < 20° .....	.29-25 log θ dBi
20° < θ < 26.3° .....	-.3.5 dBi
26.3° < θ < 48° .....	.32-25 log θ dBi
0 > 48° .....	-.10 dBi (averaged)
Antenna Noise Temperature	
10° Elevation .....	.85K
20° Elevation .....	.69K
30° Elevation .....	.56K
Cross Polarization Isolation within 1.0 dB Beamwidth	
RX .....	.22 dBi
TX .....	.25 dBi
Isolation Port to Port	
RX .....	.80dB
TX .....	.90dB
Output Waveguide Interface Flange	
RX .....	.WR42
TX .....	.WR28

69cm Extended Rx/Tx Ka-Band Antenna

**Mechanical Performance**

Reflector Material .....	Steel
Antenna Optics .....	.One-Piece Offset Feed Prime Focus
Mast Pipe Size .....	.2" or 2 3/8" Diameter
Elevation Adjustment Range .....	.5°-90° Continuous Fine Adjustment
Azimuth Adjustment Range .....	.360° Continuous Course Adjustment ± 5° Fine Adjustment

**Enviromental Performance**

Wind Loading	
Operational .....	.45 mph (72 km/h)
Functional Survival .....	.80 mph (128 km/h)
Ultimate Survival .....	125 mph (201 km/h)
Temperature (operational) .....	-.40° to 140°F (-40° to 60)°C
Rain (operational) .....	.1/2"/hr
Atmospheric Conditions .....	Salt, Pollutants and Contaminants as Encountered in Coastal and Industrial Areas
Relative Humidity .....	0 to 100% with Condensation
Solar Radiation .....	.360 BTU/h/ft²

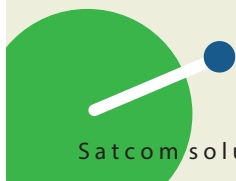

Satcom solutions for the long haul



REV 03/15-01  
Page 2 of 2