

2.4 Meter Series 1253 Polar Truss Mount

E	Revised Company Name and Logo	7/7/09	RAH
D	Revise Parts List	8/21/02	CLT
C	Revise Fig on page 17	4/16/02	RAH
B	Chgd fig 3.4-2,3.4-3,3.4-5 per ECN 2552	10/19/99	NAC
A	Added statement to C/Ku feed instructions	4/14/98	PGW
-	ORIGINAL RELEASE	7/22/96	PGW
REV.	DESCRIPTION	DATE	APPROVED

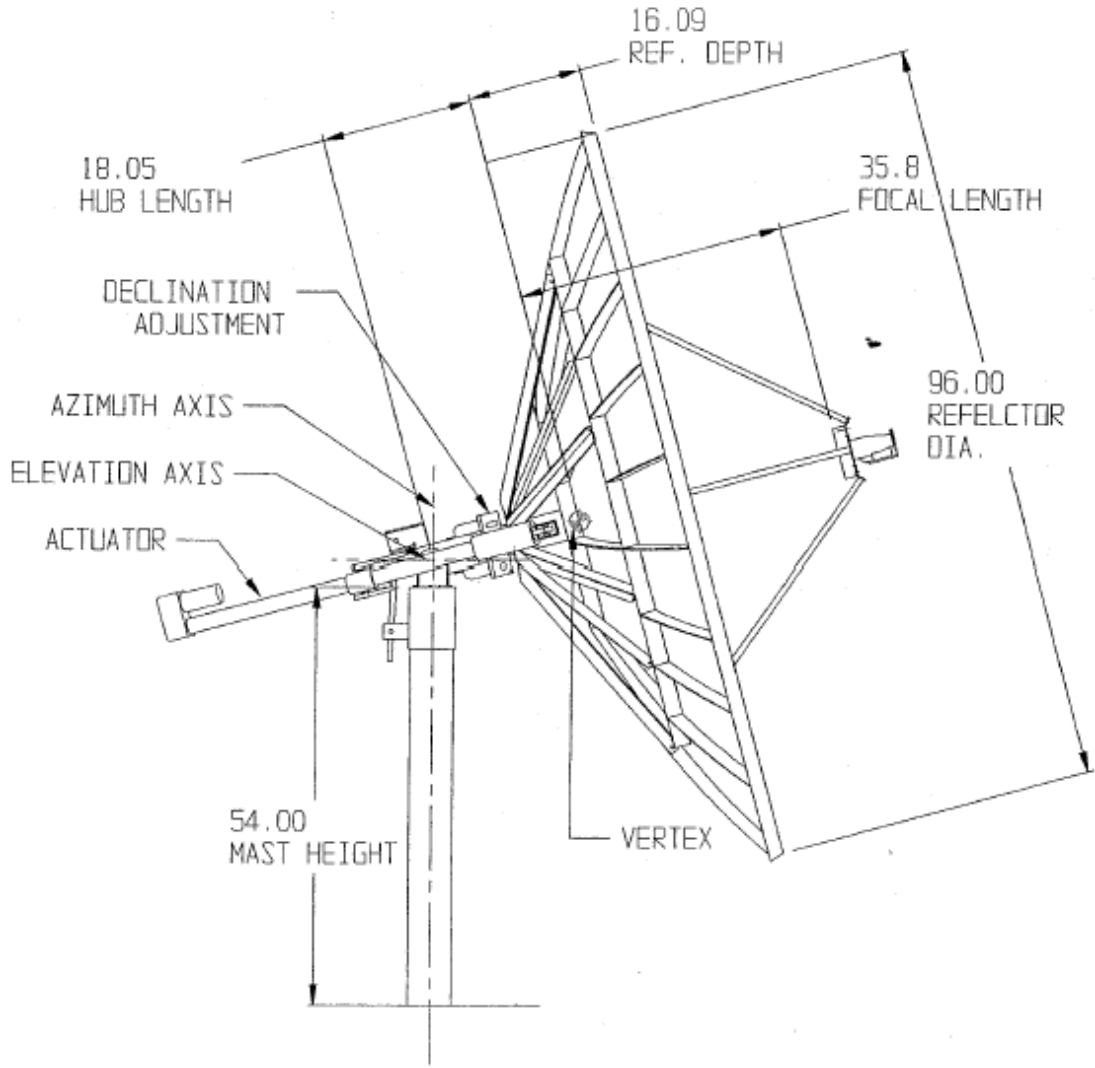

TABLE OF CONTENTS

<u>SECTION</u>	<u>TITLE</u>
I	GENERAL INFORMATION
1.1	Unpacking & Inspection
1.2	Tools Required
1.3	Site Selection
1.4	Foundation Requirements
II	REFLECTOR AND SUPPORT STRUCTURE ASSEMBLY
2.1	Reflector Pre-Assembly
2.2	Reflector Assembly
2.3	Reflector Support Structure Assembly
2.4	Reflector And Support Structure Parts List
III	REFLECTOR INSTALLATION
3.1	Canister/Elevation Rod Assembly
3.2	Polar Axis Joint
3.3	Reflector Positioning
3.4	Gimbal & Actuator Assembly
3.5	Reflector Mount Parts List Table
3.6	Gimbal Mounting Parts List Table
IV	FEED INSTALLATION
4.1	Feed Horn Assembly
4.2	Feed Support Assembly
4.3	Feed Installation
4.4	Feed Cover Installation
4.5	Feed System Parts List
V	ANTENNA ALIGNMENT AND TUNING
5.1	Declination and Elevation Adjustment
5.2	Azimuth Adjustment
5.3	Fine Tuning
5.4	Reflector Fine Adjustment

SECTION I GENERAL INFORMATION

1.1 Unpacking And Inspection

1. **Unpacking & Inspection** - The antenna containers should be unpacked and inspected at the earliest date to ensure that all material has been received and is in good condition. A complete packing list for each major component is supplied.

2. **Freight Damage** - Any damage to materials while in transit should be immediately directed to the freight carrier. He will instruct you on the matters regarding any freight damage claims.

3. **Material - Missing Or Damaged** - Any questions regarding missing or damaged materials that is not due to freight carrier should be directed to General Dynamics' Customer Service Department at:

<http://www.SatelliteDish.com> 954-941-8883

1.2 Tools Required

<u>Required Tool List Table 1.2</u>			
TOOLS	SIZE	FOR USE ON	TORQUE SPECS.
COMB.WRENCH	5/16"	#6 HARDWARE ON FEED	8 IN/LBS
COMB.WRENCH	7/16"	1/4" BOLTS ON CENTER HUB PLATE	49 IN/LBS
COMB.WRENCH	5/8"	5/8" SQ. HD. BOLTS ON CANISTER	70 FT/LBS
COMB. WRENCH & SOCKET	9/16"	3/8" BOLTS ON REFLECTOR AND SUPPORT STRUCTURE	15 FT/LBS
COMB. WRENCH & SOCKET	3/4"	1/2" BOLTS ON FEED SUPPORT AND ELEVATION ADJUSTMENT	35 FT/LBS
COMB. WRENCH	1-1/8"	ELEVATION ADJUSTMENT	N/A
ADJ. WRENCH	10"	WHEREVER APPLICABLE	
RACHET	3/8"		
INCLINOMETER	N/A	ELEVATION ADJUSTMENT	
COMPASS	N/A	AZIMUTH ADJUSTMENT	
GLOVES		1 PAIR EACH PERSON	
LADDER	8 FT.	MOUNTING FEED	

NOTE: The Minimum Torque applied should not be less than 10% of maximum recommended torque.

1.3 Site Selection

In order to achieve maximum performance of your antenna system, it is important to select the correct location for the antenna. The following guidelines should be observed when selecting a site for the installation.

1. The line of site to the satellite should be clear of any obstructions, such as trees or buildings.
2. The site should be relatively flat and level for ease of installation and access to the antenna.
3. The site should be checked for underground obstruction, such as buried cables or pipes.

4. All local building codes should be adhered to (i.e. grounding, foundation requirements, zoning rules, setbacks, etc.).

1.4 Foundation Requirements

General Dynamics' recommended foundation for the antenna system is shown in figure 1.4-1. However, each installation must be tailored to the specific requirements of the site. It may be necessary to contact a local engineer or building department for foundation design or approval at any particular site.

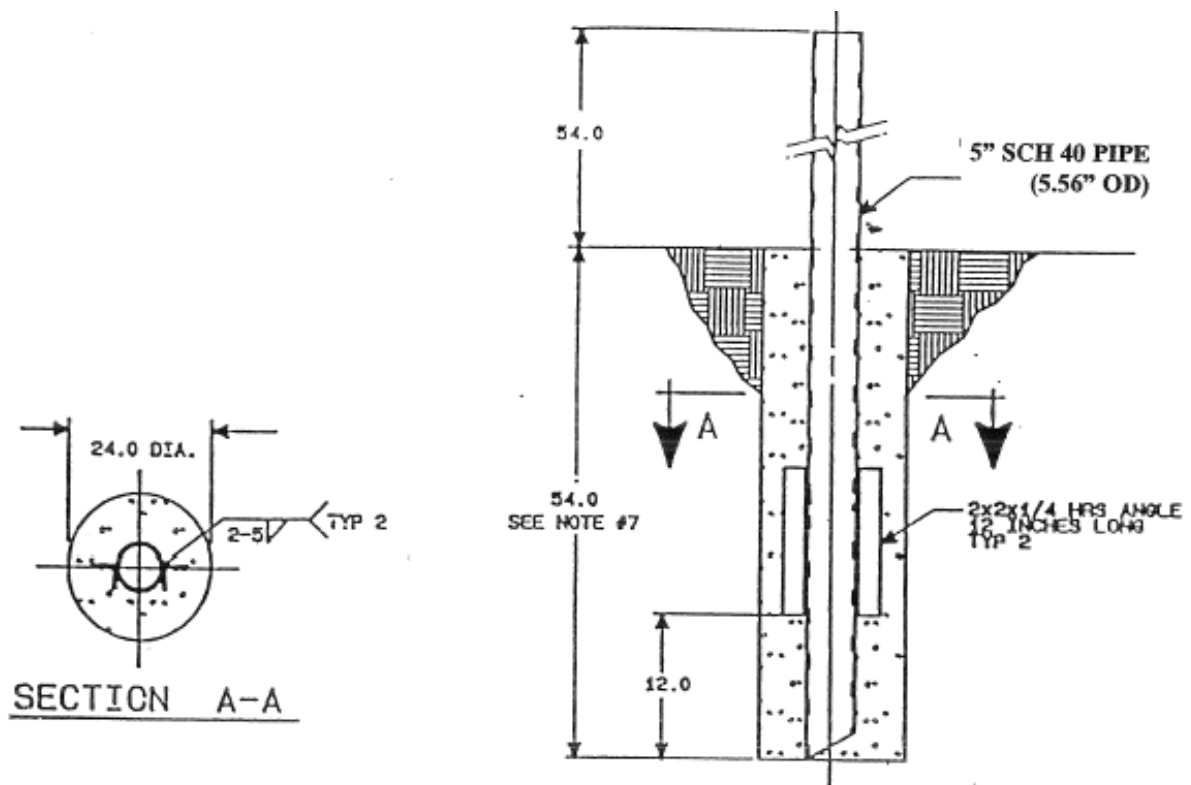

NOTES:

1. 2 x 2 x 1/4 HRS Angle and schedule 40 pipe should conform with ASTM A36 structural steel.
2. All concrete should conform to building code standards and have a minimum compressive strength of 3000 PSI at 28 days. (Per ACI-318-77)
3. Soil bearing capacity should be no less than 2000 PSF.
4. Concrete should be poured against undisturbed soil.
5. Allow concrete 24 hours set time before installation of antenna.
6. The antenna should be properly grounded to meet applicable local codes.
7. Minimum depth as shown or extend to local frost line.

GENERAL DYNAMICS DOES NOT REPRESENT OR WARRANT THAT ANY PARTICULAR DESIGN OR SIZE OF FOUNDATION IS APPROPRIATE FOR ANY LOCALITY OR EARTH STATION INSTALLATION

SECTION II REFLECTOR AND SUPPORT STRUCTURE ASSEMBLY

NOTE: Assembly of the reflector should be on a level surface to prevent warping or misalignment of the reflector's parabolic shape during assembly. Any loss of contour may affect the antenna's signal quality. If a level surface is not available, refer to section 5.4 for tips on how to check the reflector shape and correct it if necessary.

2.1 Reflector Pre-Assembly

1. The reflector consists of three interchangeable petals of compression molded glass-fiber reinforced material. This material is very strong, yet the reflector is lightweight and easy to handle. The reflector will possess a very accurate parabolic shape when properly assembled, and will retain this shape for years under adverse environmental conditions. The microwave reflective surface is provided by a molded- in fine mesh screen that lies just beneath the surface of the petals.
2. Identify the reflector petals and parts of the reflector support structure according to the parts list in table 2.4.
3. The reflector petals have a 1/2" hole through the center. These holes are for the feed clevises. Pre-assemble the reflector petals as follows:
4. Run the 1/2" nut (item #6) up the threads of the clevis (item #2), and place a 1/2" flat washer (item #7) against the nut. Adjust the nut until the distance from the far side of the washer and the center of the clevis hole is 1.5".
5. Place the clevis assembly through the hole in the reflector petal from the front and secure with the 1/2" flat washer, lock washer, and nut (item #'s 7, 8, & 6) as shown in figure 2.1-1. Tighten these nuts hand tight only at this time.

2.2 Reflector Assembly

1. Place two petals (item #1) rim down on the level surface with their flanges next to each other. The petals are free-standing with the rim down and the center up (figure 2.2-1). Begin assembly of the flange with the 3/8 hardware (item #'s 12,13,14,15) as shown in figure 2.2-2. You will notice that the hardware is a close fit in the reflector holes. This insures an accurate assembly of the reflector petals. If necessary, gently tap or thread the hardware through these holes. Only install hardware at location A,B,D and E of figure 2.2-1 at this time. This hardware may be fully tightened now.
2. Place the polar hub (item #3) on the center of the two petals, and attach the center plate (item #4) to the front with the 1/4 hardware (item #'s 9,11,10) as shown in figure 2.3-1. Do not tighten this hardware now; leave it loose enough to rotate the hub in the reflector.
3. Place the third petal in position, insuring that the lip on its inner edge is located between the center hub and plate. Attach this petal to the other two using the 3/8 hardware (item #'s 12,13,14,15) as above. Tighten this hardware now. At this time, the reflector assembly is strong enough to sustain the weight of the installer; however, step only on the ribs, not on the surface between the ribs.

2.3 Reflector Support Structure Assembly

NOTE: **Gloves are strongly recommended during this assembly procedure.**

1. Attach one of the angle braces (item #5) to the hub as shown in figure 2.3-1 with 3/8" hardware (item #12,13,14,15). Note that the notched end of the angle goes toward the reflector.
2. Rotate the hub if necessary to position the angle next to the reflector's rib and attach at reflector location "C" with 3/8" hardware. (item #12,13,14,15)
3. Attach the remaining 5 angle braces in the same manner.
4. Tighten all hardware completely. Including the six 1/4" bolts at the reflector center hub.

2.4 Reflector And Support Structure Parts List

Reflector And Support Structure Parts List Table 2.4			
ITEM #	PART NO.	DESCRIPTION	QTY
1	0179-173	Reflector Petal	3
2	0217-072	Feed Support Clevis	3
3	0490-599	Polar Hub Weldment	1
4	0156-808	Center Plate	1
5	0225-553	Angle Brace	6
6	8104-007	1/2-13 Hex Nut	6
7	8201-043	1/2" Flat washer	6
8	8202-043	1/2" Lock washer	3
9	8030-010	1/4-20 X 1.25" Bolt	6
10	8201-040	1/4" Flat washer	6
11	8202-040	1/4" Lock washer	6
12	8032-010	3/8-16 X 1.25" Bolt	24
13	8201-042	3/8" Flat washer	48
14	8202-042	3/8" Lock washer	24
15	8102-007	3/8-16 Hex Nut	24

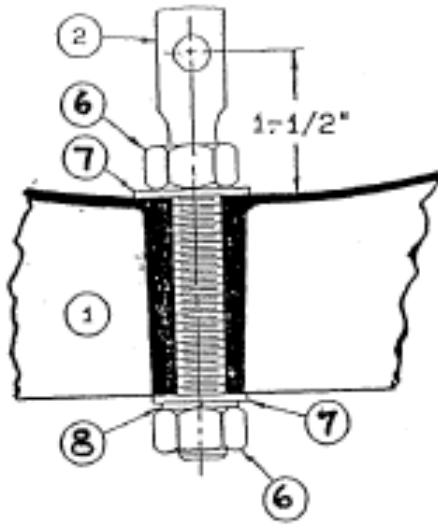

FIGURE 2.1-1

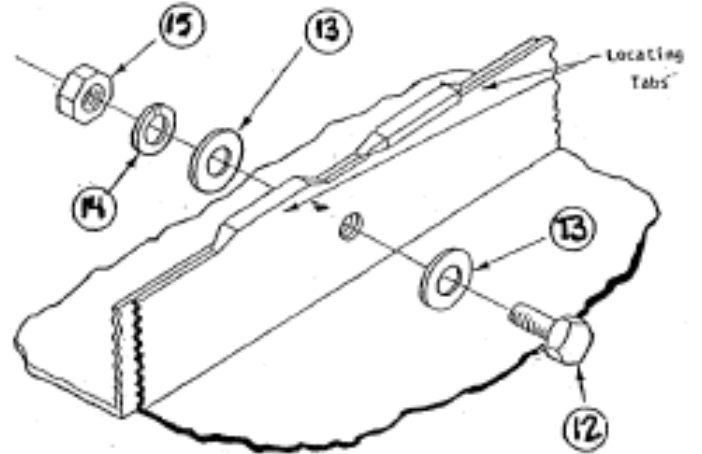

FIGURE 2.2-2

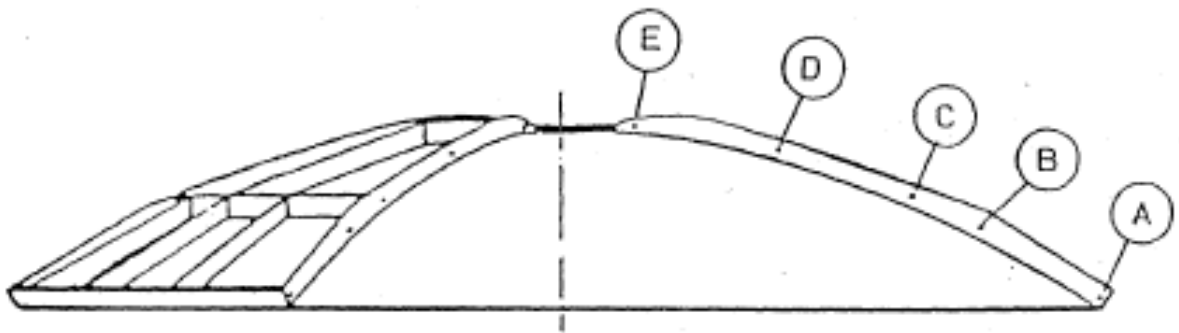

FIGURE 2.2-1

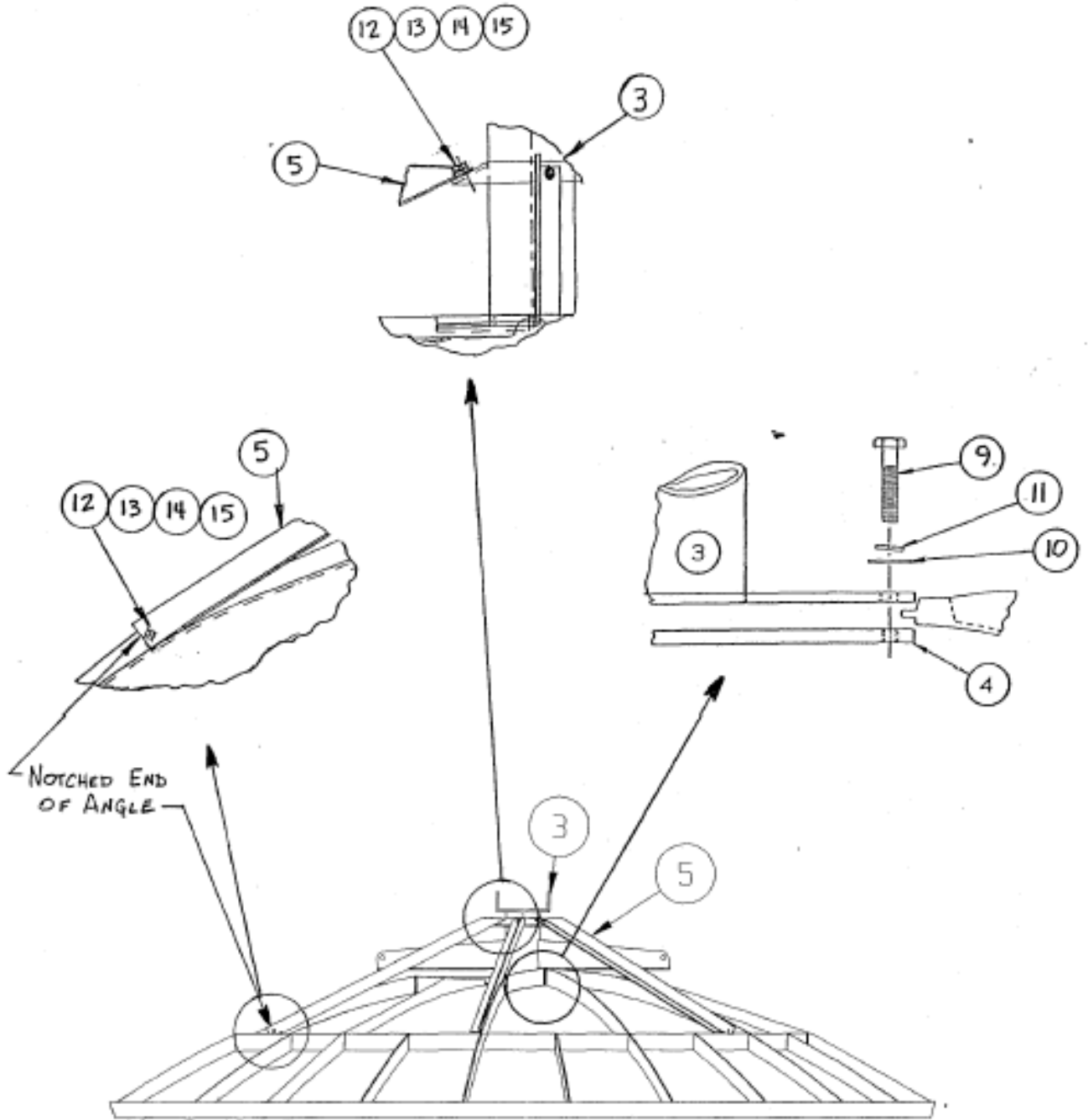

FIGURE 2.3-1

SECTION III REFLECTOR INSTALLATION

NOTE: At least three persons are recommended for the installation of the antenna on the mast. After the reflector is positioned on the canister, two can steady the reflector while the other secures it.

3.1 Canister & Elevation Rod Assembly

1. Refer to the reflector mount parts list (table 3.5) and figure 3.1-1 to identify the parts needed. Insert each square head screw (item #4) into the canister (item #1), only a few turns, so that the bolts do not extend into the canister, and position it on the mast. Insure it rotates freely and is seated all the way down on the mast pipe.
2. Assemble the elevation adjustment block (item #2) to the canister by placing it between the ears of the canister and securing with two 1/2-13 x 1.25" bolts, flat washers, and lock washers (items #5,7,8).
3. Run a 5/8-11 hex nut (item #13) well up onto the elevation adjustment rod (item #3) and slide the rod through the hole in the elevation adjustment block. Secure by placing a second 5/8-11 hex nut onto the bottom of the rod.

3.2 Polar Axis Joint

1. Run a 1/2-13 hex nut (item #9) onto the rod end (item #19). Place a 1/2" (item #7) flat washer onto the rod before inserting through the hole in the bracket on polar axis joint. Snug with another 1/2" flat washer and 1/2-13 hex nut.

Figure 3.2-1

2. Attach the polar axis joint (item #14) to the polar hub (item #3 table 2.4) with [4] 5/8-11 x 1.50" bolts, [8] flat washers, and [8] nuts (items #15,16,17,18). Snug the hardware to secure the channels. Figure 3.2-2
3. Attach the rod end to the tab on the polar hub channel with a 3/8-16 x 1.25" bolt, flat washers, lock washer, and hex nut (items # 20,21,22,23). Tighten the bolt. Figure 3.2-3

3.3 Reflector Positioning

1. Bring the completed reflector assembly to the mast, and locate it about 1-1/2 to 2 feet from the mast. Make sure that the elevation bracket on the hub is oriented toward the top of the reflector away from the mast. Use the reflector carton (or similar object) as a rest under the edge of the reflector (see figure 3.3-1). Have the 1" hardware (item #'s 10,11,12) close at hand.
2. Swing the reflector up until the polar axis joint can be placed between the top bracket of the canister, as shown in figure 3.3-2. Align the hole in the polar axis joint with the hole in the canister and secure with the 1" hardware.
3. Raise or lower the reflector until you can place the elevation adjustment rod in the channel on the polar axis joint and secure with 1/2-13 x 3.00" bolts, flat washers, lock washers and hex nuts (item #'s 6,7,8,9) as shown in figure 3.3-2. Do not tighten these bolts until section 5.1.

3.4 Gimbal & Actuator Assembly

Refer to gimbal mounting parts list (table 3.6) and figure 3.4-1 to identify the parts.

The recommended actuator should be a 36" stroke ball screw type with a 2" diameter barrel. Dynamic thrust: 1500 lb. Static load: 3000 lb

Depending upon your location, the actuator mounting plate is installed in one of two positions on the polar axis joint: looking from behind the antenna, for locations in the eastern half of the U.S., mount the plate on the right; for locations in the western half of the U.S., mount the plate on the left. (See figure 3.4-1)

1. Attach the plate (item #1) to the polar axis joint with two 1/2-13 x 1.50" bolts, flat washers, lock washers and hex nuts (items #12,14,15,16). Figure 3.4-2
2. Attach the gimbal spacer plate (item #3) to the actuator mounting plate with two 5/16-18 x 1.00 bolts and lock washers (items #10, 11). Figure 3.4-3
3. Remove the motor, slide the gimbal (item #4) on to the barrel of the actuator. Insert the 3/8-16 x 2.00" bolts, lock washers and hex nuts into the gimbal. Reattach the motor.
4. Rotate the barrel until the motor is in the vertical position **with the arrow pointed up.** Tighten bolts.

5. Attach the actuator to the polar hub. Use two spacers (item # 6) on top and bottom of the ball clevis on the actuator. Secure in place with the 1/2-13 x 2.75" bolt, flat washers, lock washer and hex nut (items # 13,14,15,16). Tighten bolt. Let the actuator hang for the moment. Figure 3.4-4

6. Slide the gimbal mounting plate (item #2) through the bushing and onto the bottom stud of the gimbal (item #4). Hold the plate in place, raise the plate and actuator up to the gimbal spacer plate (item #3). Before inserting the other stud into the bushing in the actuator mounting plate (item #1), slide the brass washer (item #5) onto the stud. Align the holes and fasten the two plates together with two 5/16-18 x 1.00" bolts and lock washers (item #10,11). Tighten bolts. Figure 3.4-5.

3.5 PARTS LIST TABLE

REFLECTOR MOUNT PARTS LIST TABLE 3.3			
ITEM NO.	PART NO.	DESCRIPTION	QTY
1	0490-502	CANISTER	1
2	0168-085	ELEVATION ADJ. BLOCK	1
3	0490-476	ELEVATION ADJUSTMENT ROD	1
4	8317-105	5/8-11 x 2.00" SQ HD SCREW	6
5	8033-010	1/2-13 x 1.25" BOLT	2
6	8033-024	1/2-13 x 3.00" BOLT	1
7	8201-030	1/2" Flat washer	4
8	8202-043	1/2" Lock washer	5
9	8104-007	1/2-13 Hex Nut	3
10	8036-048	1-8 X 6.00" Bolt	1
11	8202-046	1" Lock washer	1
12	8107-007	1-8 Hex Nut	1
13	8105-007	5/8-11 Hex Nut	2
14	0181-880	Polar Axis Joint	1
15	8034-012	5/8-11 x 1.50" Bolt	4
16	8201-039	5/8" Flat washer	8
17	8202-044	5/8" Lock washer	4
18	8105-007	5/8-11 Hex Nut	4
19	0217-071	1/2-13 Rod End	1
20	8032-010	3/8-16 x 1.25" Bolt	1
21	8201-042	3/8" Flat washer	2
22	8202-042	3/8" Lock washer	1
23	8102-007	3/8-16 Hex Nut	1
24	8201-046	1" Flatwasher	2

3.6 Parts List Table

Gimbal Mounting Parts List Table			
Item No.	Part No.	Description	Qty
1	0156-170	Actuator Mounting Plate	1
2	0181-881	Gimbal Mounting Plate Assy	1
3	0156-171	Gimbal Spacer Plate	1
4	4080-043	Gimbal	1
5	8201-069	1/2" Flat Washer (Brass)	1
6	0162-173	Spacer	2
7	8032-016	3/8-16" X 2.00 Bolt	2
8	8202-042	3/8" Lock Washer	2
9	8102-007	3/8" Hex Nut	2
10	8031-008	5/16" - 18 X 1.00 Bolt	6
11	8202-041	5/16" Lock Washer	6
12	8033-012	1/2-13 X 1.50 Bolt	2
13	8033-022	1/2-13 X 2.75 Bolt	1
14	8202-030	1/2" Flat Washer	4
15	8202-043	1/2" Lock Washer	3
16	8104-007	1/2" Hex Nut	3

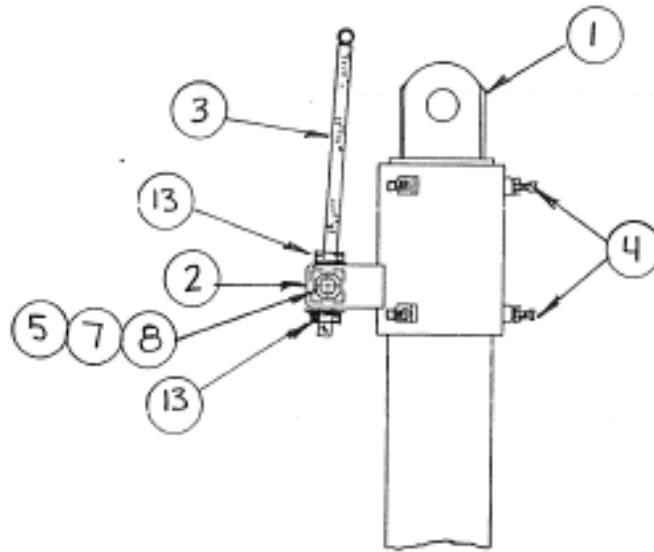

Figure 3.2-1

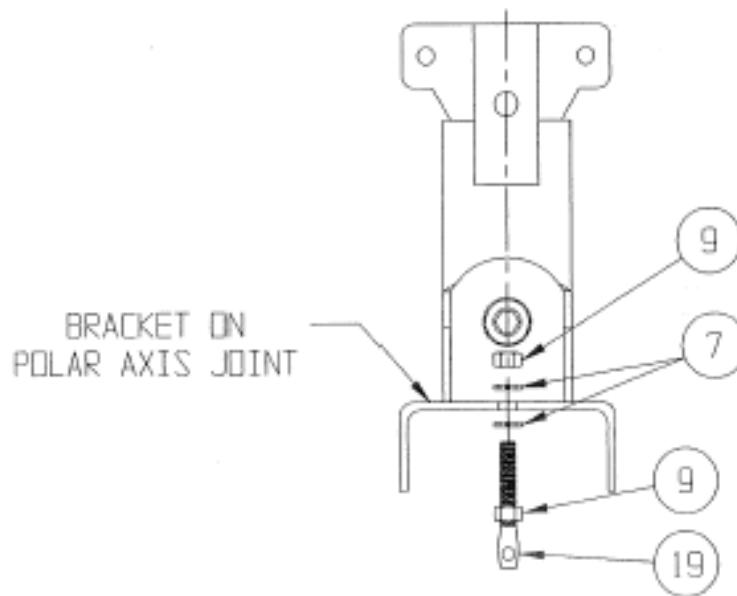

Figure 3.3-1

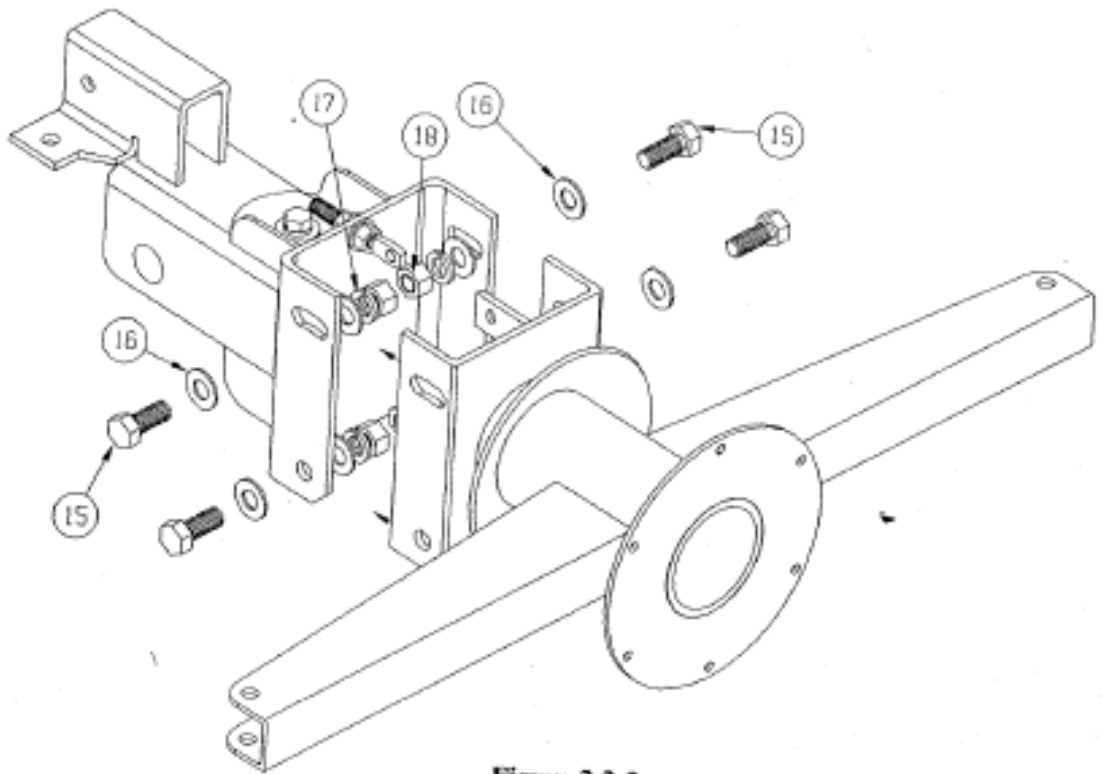

Figure 3.3-2

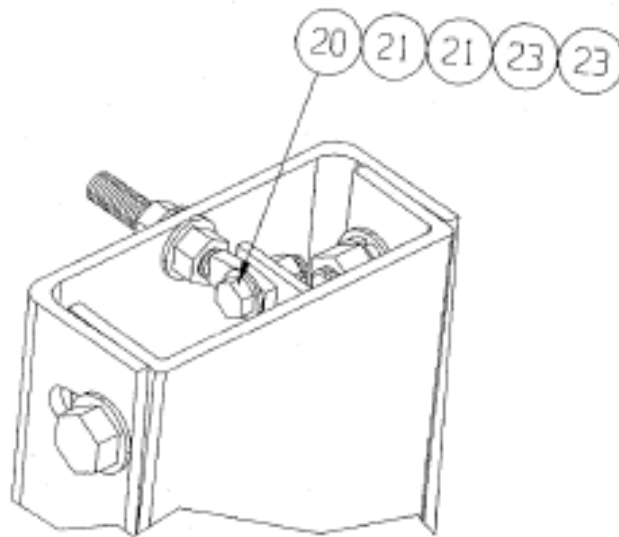

Figure 3.3-3

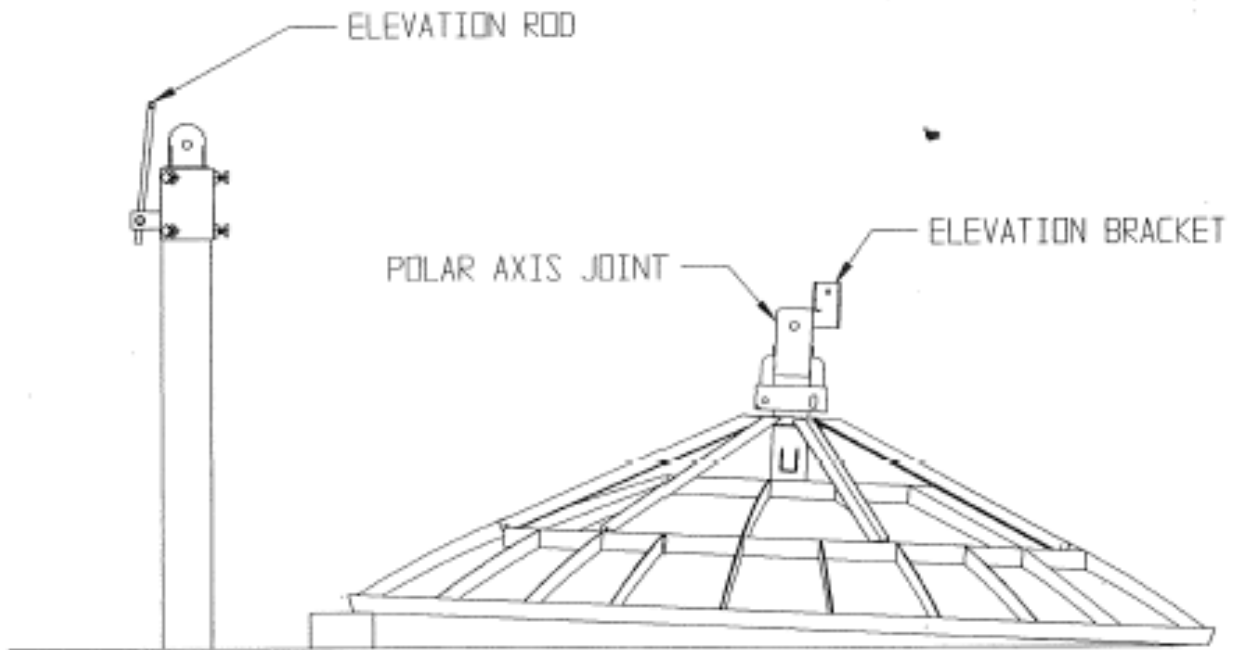

Figure 3.4-1

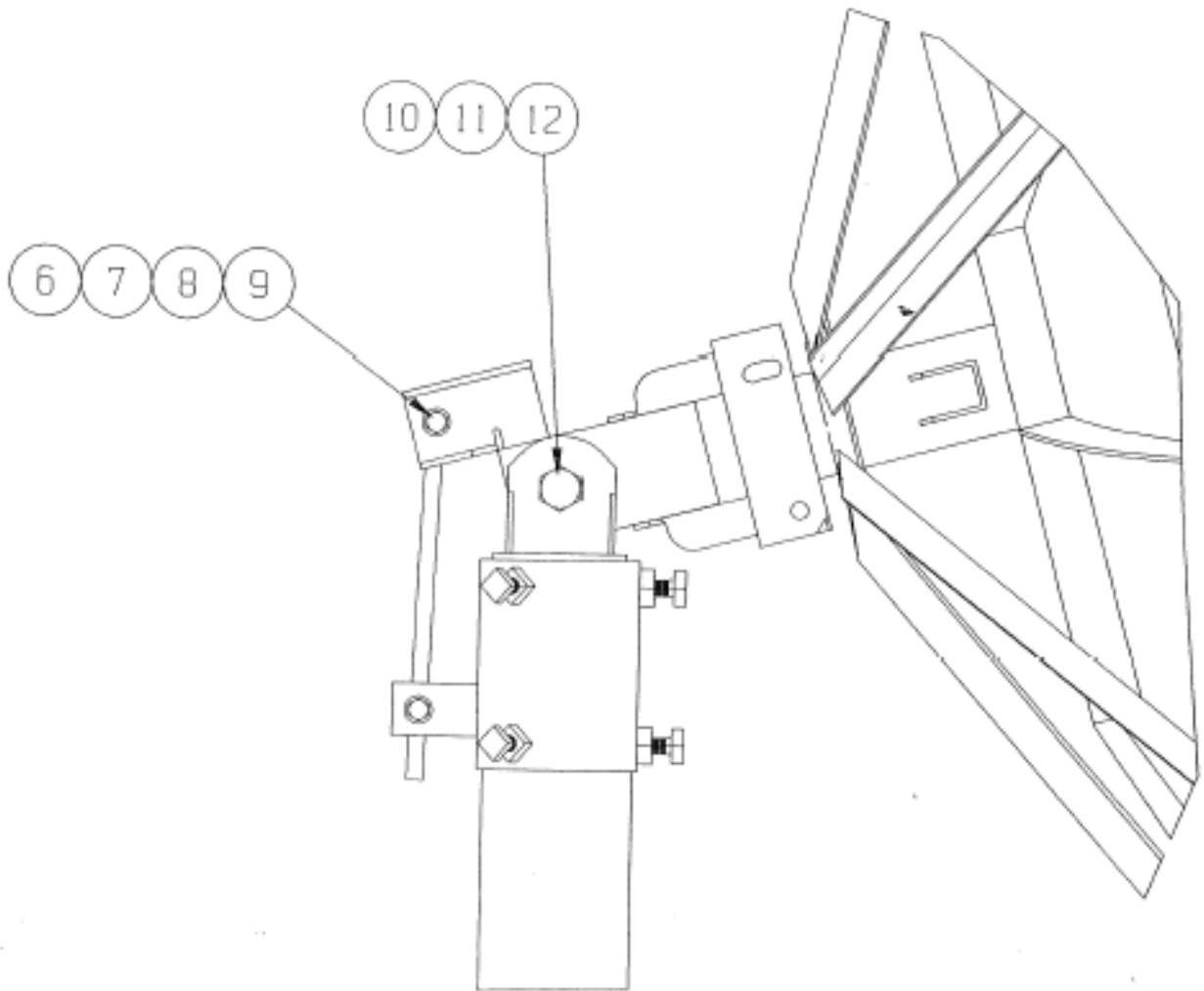

Figure 3.4-2

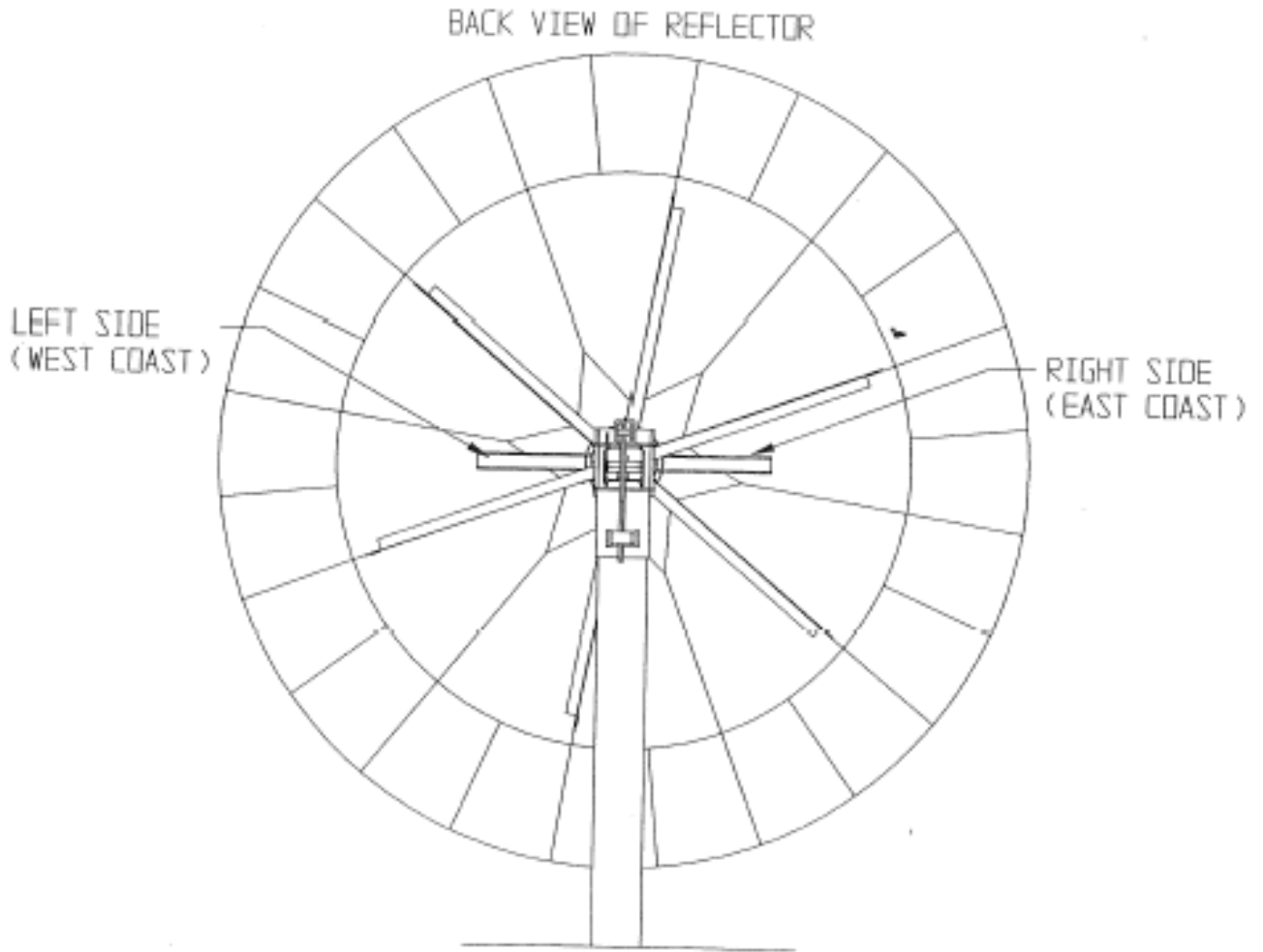

Figure 3.5-1

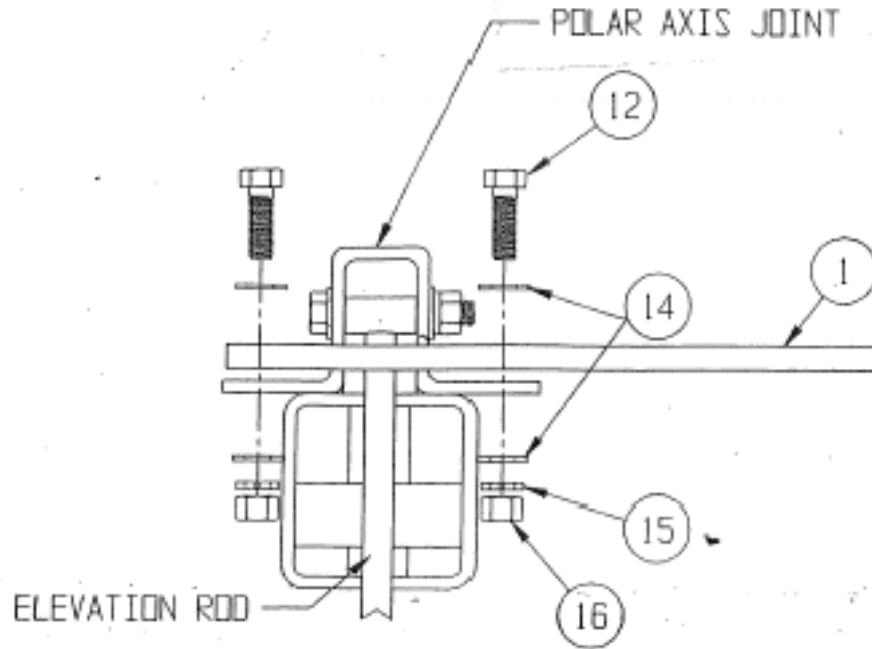

Figure 3.5-2

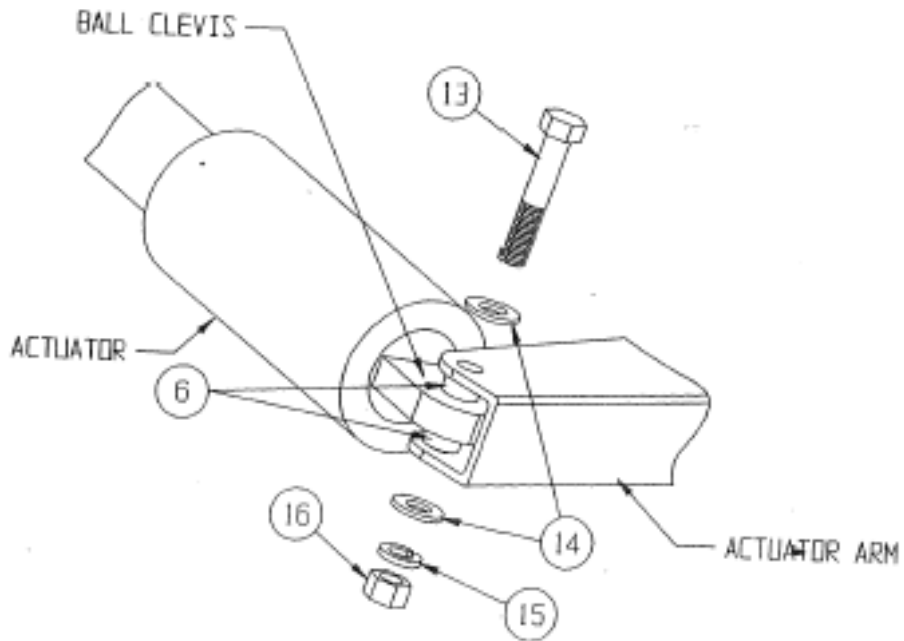

Figure 3.5-3

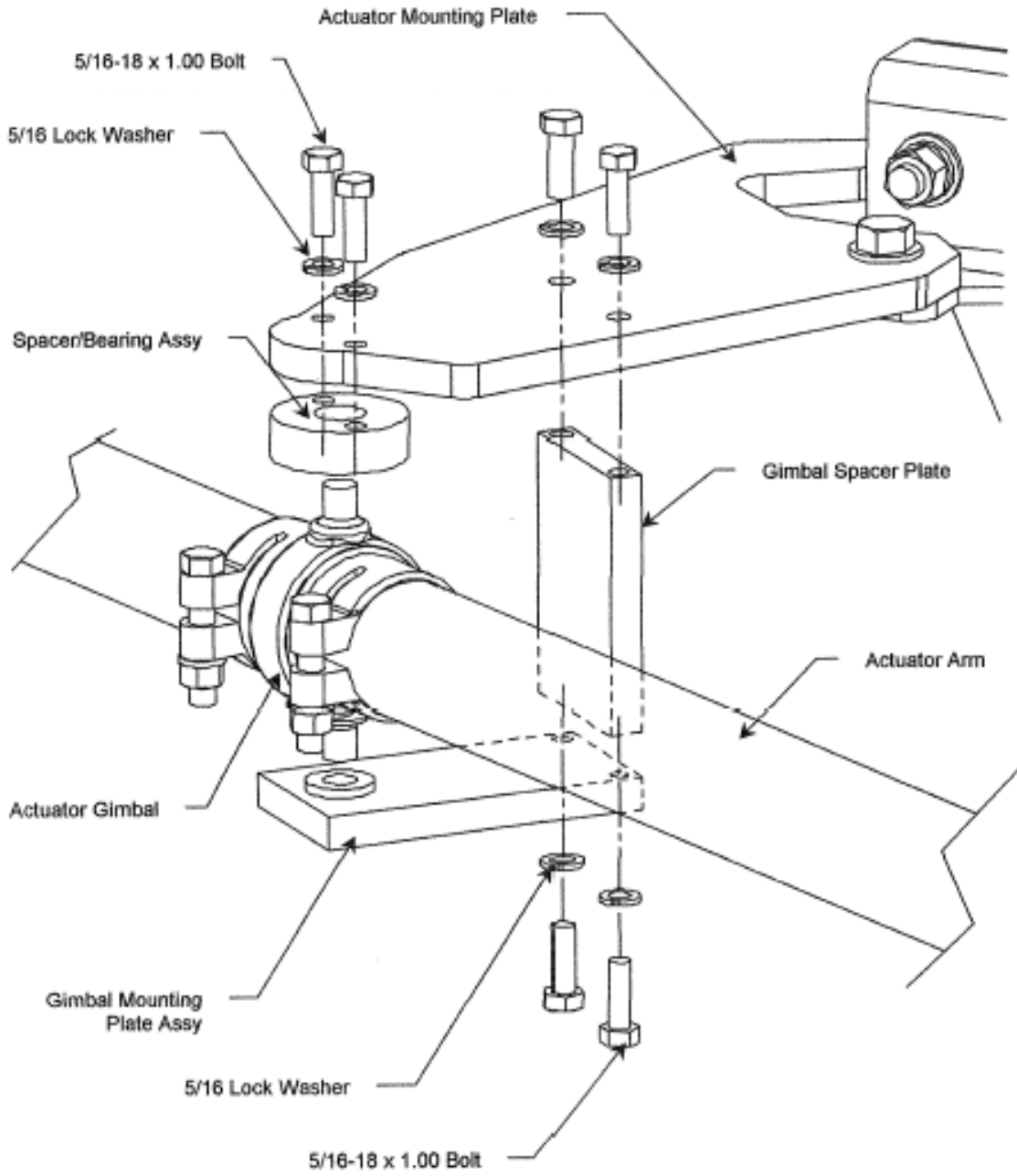

Figure 3.5-4

SECTION IV FEED INSTALLATION

4.1 Feed Horn Assembly

Ku-Band Feed

SINGLE POLE - Coat the o-ring (item #2) with the silicone grease from the capsule provided and place it in the feed horn o-ring groove. Place the square adapter (item #3) on the feed horn flange and line up the four hole pattern in the adapter with four of the eight holes in the feed horn flange. (Note that the adapter will only line up one way.) Place the LNB (customer provided) on the adapter so that the holes in the LNB line up with the feed/adapter holes and secure with four screws (item #4). See figure 4.1-1. Tighten securely.

Ku-BAND - SINGLE POLE - PARTS LIST			
ITEM #	PART #	DESCRIPTION	QUANTITY
1	0183-277	Feed Horn Assembly	1
2	0198-120	O-Ring	1
3	0202-067	Transition Adapter	1
4	8300-017	#6-32 X 7/8" SS STD	7
5	8200-010	#6 Lock washer	7

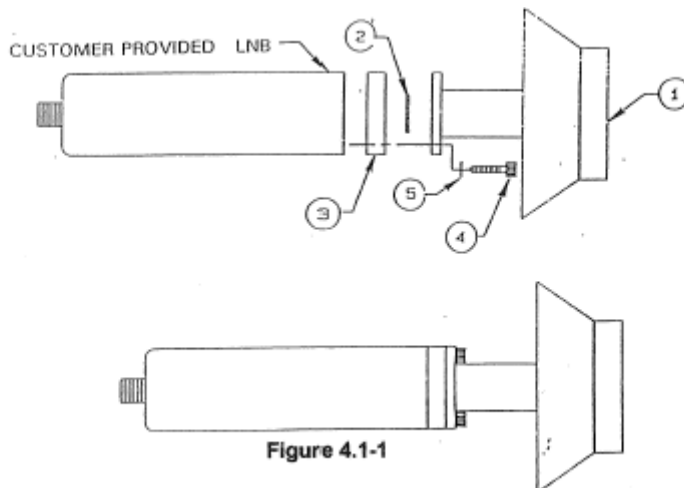

Ku-BAND FEED

DUAL POLE - Coat the o-ring (item #6) with the silicone grease from the capsule provided and place it in the feed horn o-ring groove. Attach the OMT (item #1) to the feed horn (item #2) with the #6 hardware (item #'s 3,4,& 5). Attach two LNB's (customer provided) to the OMT with the o-rings and hardware provided with the LNB's. See figure 4.1-2. Tighten securely.

Ku-BAND - DUAL POLE - PARTS LIST			
ITEM #	PART #	DESCRIPTION	QUANTITY
1	4080-045	OMT, Ku-BAND - DUAL - RECEIVE	1
2	0183-276	Feed Horn Assembly	1
3	8300-002	#6-32 X .50 S.S. STD. Screw	7
4	8200-010	#6 Lock washer	7
5	0198-120	O-Ring	1

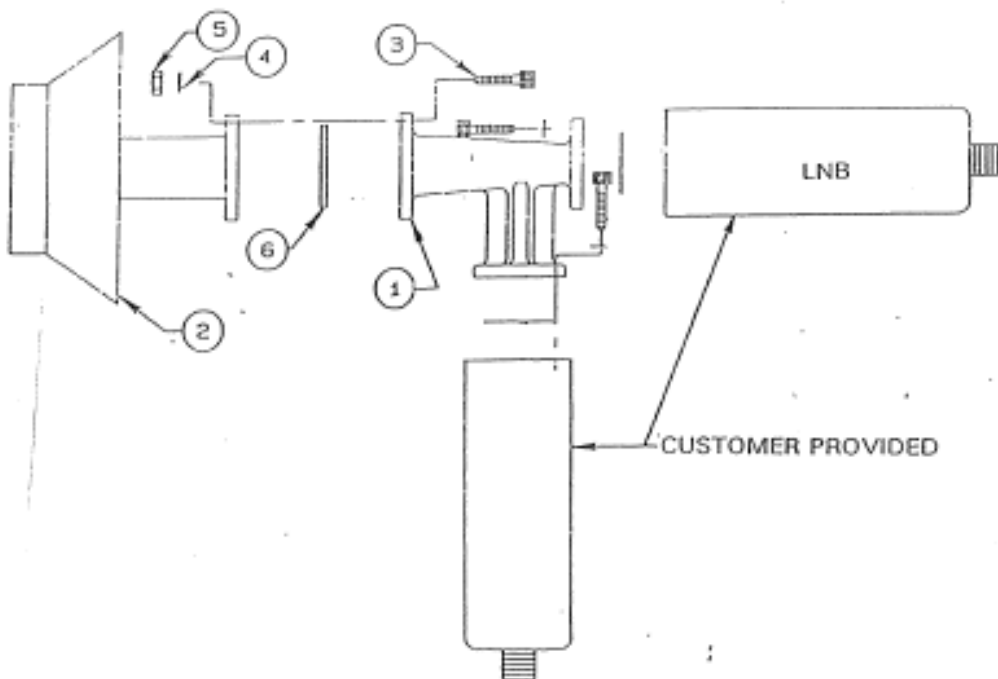

Figure 4.1-2

C-Band Feed

Attach the LNB's (customer supplied) to the feed horn flange with the 1/4" hardware and gaskets (item #'s 2,3,4,5,& 6) provided. See figure 4.1-3. (SINGLE POLE ONLY - Attach the cover plate (item #7) and gasket (item #2) to the bottom of the feed horn as shown.) Tighten securely.

C-BAND - PARTS LIST			
ITEM #	PART #	DESCRIPTION	QUANTITY
1	0183-294	FEED HORN ASSEMBLY	1
2	0170-074	GASKET	2
3	8030-010	1/4-20 x 1.25 BOLT	20
4	8201-040	1/4" FLAT WASHER	20
5	8202-040	1/4" LOCK WASHER	20
6	8100-007	1/4-20 HEX NUT	20
7	0156-576	COVER PLATE (SINGLE POLE ONLY)	1

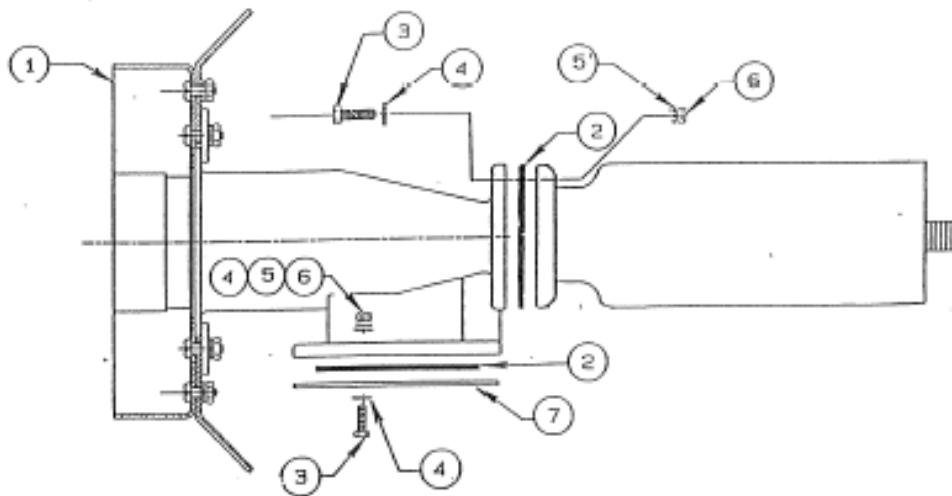

Figure 4.1-3

C/Ku-BAND FEED

Attach the four feed mounting brackets to the scalar of the C/Ku band feed (customer supplied) with the hardware provided. (Figure 4.1-5). Tighten securely. If the feed is adjustable for various f/d ratios, set it for .37

C/Ku-BAND FEED PARTS LIST			
ITEM #	PART #	DESCRIPTION	QUANTITY
1	0211-405	BRACKET, FEED SUPPORT	4
2	8030-006	1/4-20 x .75 BOLT	4
3	8202-040	1/4" LOCK WASHER	4
4	8100-007	1/4-20 HEX NUT	4

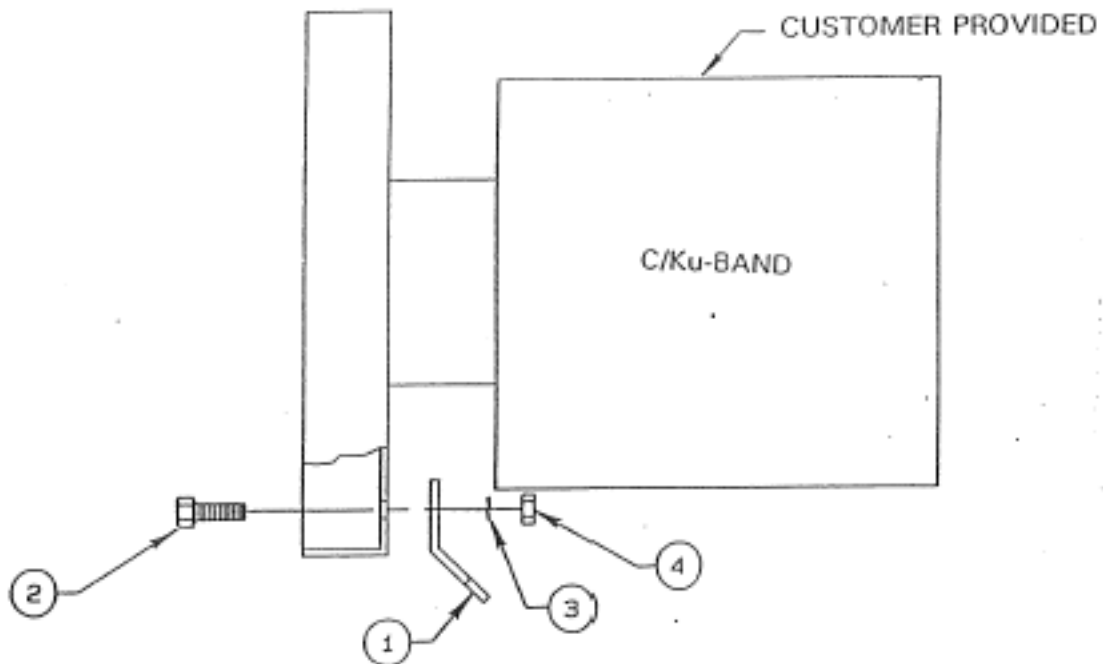
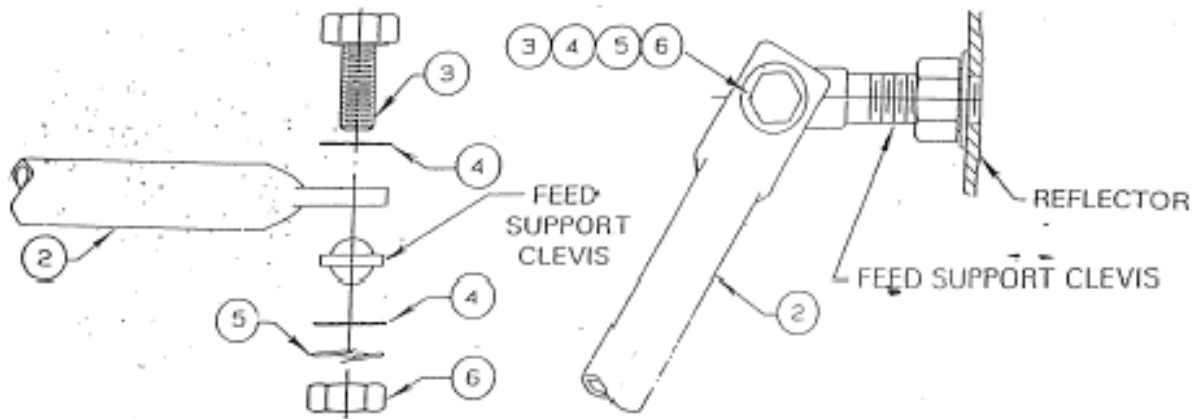

Figure 4.1-4

4.2 Feed Support Assembly

NOTE: Refer to the parts list in table 4.5 for the following sections.

1. Attach each of the feed support rods (item # 2) to the feed support clevis with the 3/8" hardware (item #'s 3,4,5,& 6). Note that each rod should be attached to the same side of the clevis (inside or outside). See figure 4.2-1.



4.3 Feed Installation

1. **Focal Length** - As shown in figure 4.3-1 through 4.3-3, attach the feed horn assembly to the three feed rods with the same 3/8" hardware as above. (For ku-band single pole only, insert the feed cover tab (item #7) between the feed horn and the 3/8" flat washer). Tighten the four bolts securely at this time. Check the focal length by measuring from the face of the feed horn to the reflector cover plate as shown in figure 4.3-4. If the focal length is incorrect, adjust the feed clevises in or out at the reflector surface as needed. Be sure that the clevises are adjusted equally. When the focal length is correct, tighten all feed support and clevis hardware securely.
2. **Polarity Adjustment** - On C-band and Ku-band feed systems, polarity is adjusted by loosening the feed horn bolts (see figure 4.3-5 and 4.3-6) and rotating the OMT or feed horn 90 degrees, then re-tighten the bolts.

4.4 Feed Cover Installation

For Single Pole Ku-Band Feed Only - After completion of the feed installation, connection of the cable and polarity adjustment, bend the feed cover tabs (item #7) in and then slide the feed cover (item #8) over the tabs. Attach the cover to the tabs with the tapping screws (item # 9) and slide the cap (item #10) over the cover as shown in figure 4.4-1.

FEED SYSTEM PARTS LIST TABLE 4.5			
ITEM NO.	PART NO.	DESCRIPTION	QUANTITY
1	VARIES	FEED HORN ASSEMBLY	1
2	VARIES	FEED SUPPORT ROD	3
3	8031-008	3/8-16 x 1.00 BOLT	6
4	8201-042	3/8" FLAT WASHER	19
5	8202-042	3/8" LOCK WASHER	6
6	8102-007	3/8" HEX NUT	6
<u>Ku-BAND SINGLE POLE ONLY</u>			
7	0156-819	FEED COVER TAB	3
8	0250-276	FEED COVER	1
9	8320-001	#8 x 1/2" TAPPING SCREW	3
10	4075-003	FEED COVER CAP	1

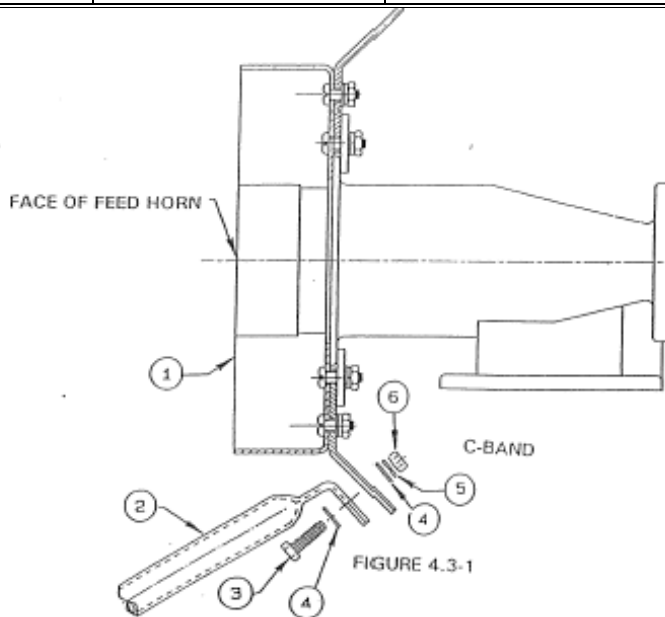

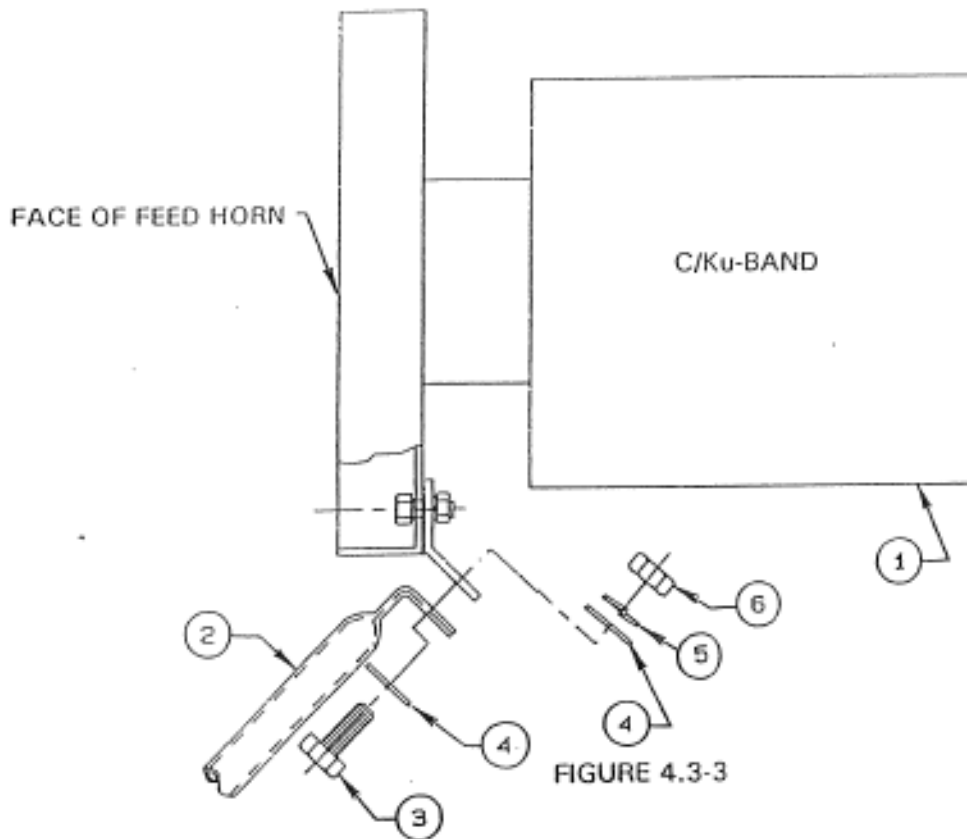
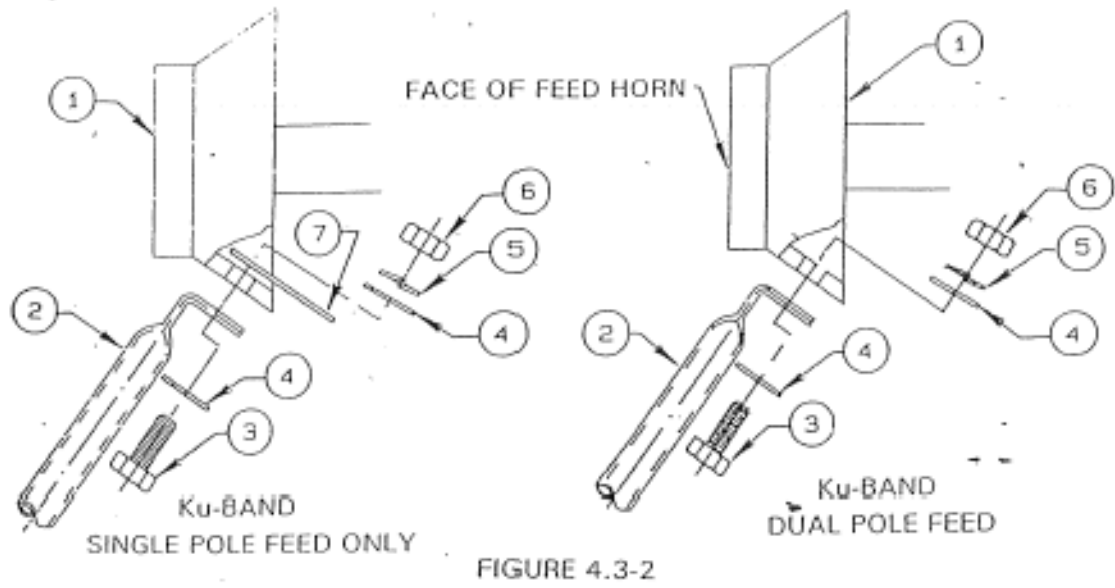

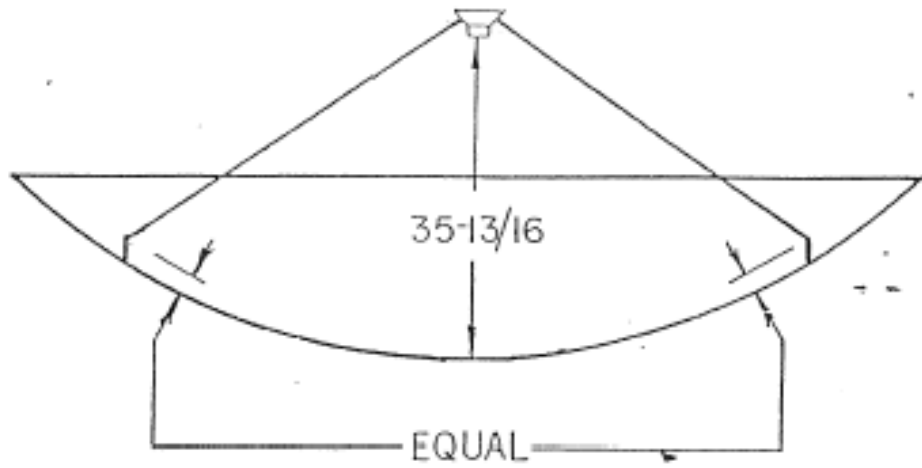

FIGURE 4.3-4

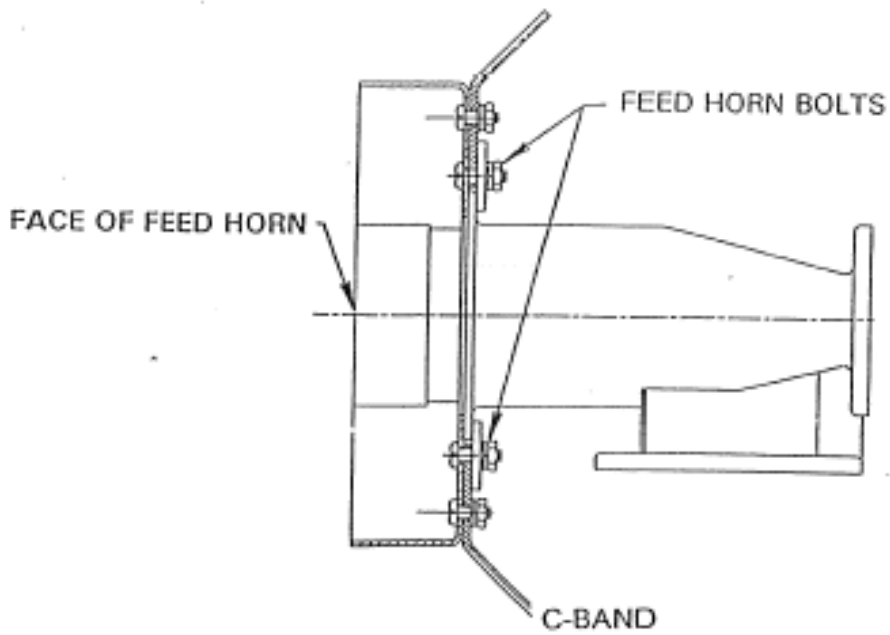

FIGURE 4.3-5

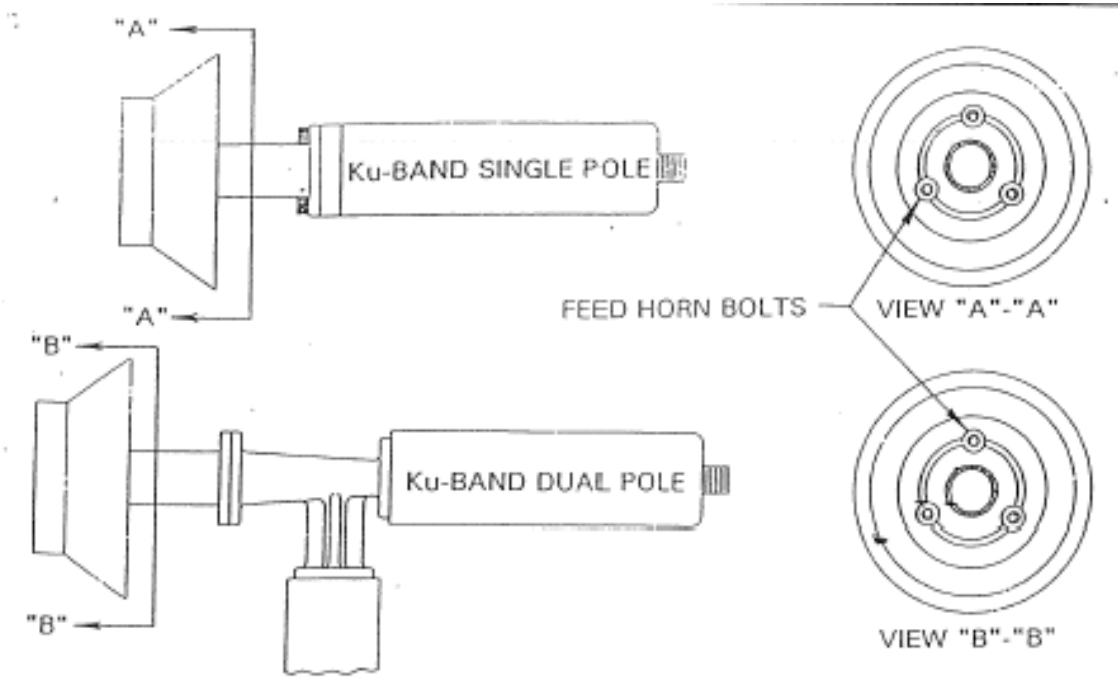
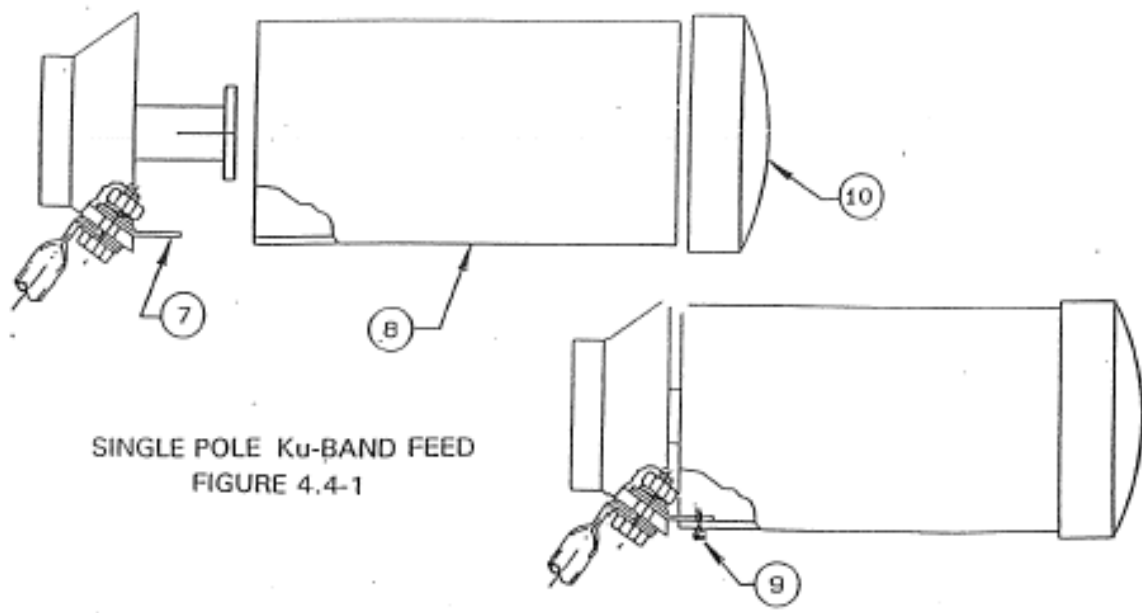

FIGURE 4.3-6



SECTION V ANTENNA ALIGNMENT AND TUNING

5.1 Elevation Adjustment

1. Set the polar axis angle to zero (due south) by sliding the actuator in the clamp. Place an inclinometer on the hub as shown in figure 5.1-1, then on the polar axis as shown. The difference between these two readings should be 90 degrees plus the declination angle. Table 5.1-1 gives the recommended declination angles as a function of site latitude. Adjust the declination rod until the correct setting is achieved, then tighten all declination hardware.
2. Set the elevation (latitude) angle by placing the inclinometer on the polar axis assembly as shown. Adjust the elevation rod until the correct elevation angle is read., as shown in figure 5.1-2. Snug the elevation axis bolt and adjustment hardware.

5.2 Azimuth Adjustment

1. Loosen the actuator clamp and slide the actuator into the clamp as far as possible (rotating the antenna about the polar axis). Rotate the barrel until motor is in a vertical position **WITH THE ARROW POINTED UP**. Tighten the actuator clamp about the barrel with the 3/8" hardware in the collar.
2. Operate the actuator until the antenna is in the correct elevation angle for a selected satellite (measured off the hub as in figure 5.1-2). Sweep the antenna in azimuth until a signal is found. Rotate the antenna in azimuth until loss of signal is observed. Rotate the antenna in the opposite direction until the signal strengthens, then weakens again. Set the azimuth midway between these two points and snug canister bolts.

5.3 Fine Tuning

After setting the azimuth, operate the actuator until another satellite is found. It is best to use two satellites at opposite ends of the arc for these adjustments. Return to the elevation adjustment and fine tune in the same way, splitting the difference between the two points where loss of signal is first observed. Operate the actuator to check reception of all satellites in the arc. It is best to adjust elevation when high in the arc (antenna east to west). Continue fine tuning elevation and azimuth until the entire arc can be tracked.

5.4 Reflector Fine Adjustment

1. As discussed in section 2, a level surface is necessary for assembly of the reflector. If a level surface is not available, the reflector may be checked for accuracy by use of strings across the aperture.
2. Use thin cord across the reflector diameter from rim to rim at four places. One end of each string should be taped to the rim just to one side of the seam between two petals. The other end should be fastened 180° opposite. All four strings should lightly touch where they cross at the center. The distance from center of the reflector (hub to plate) to the strings should be 16.09”.
3. If the reflector does not check out as described above within approximately a 1/4", reflector adjustment may be done. Identify the point on the rim that is either high or low. Loosen the bolts on the angle brace behind the radial line of the reflector. Gently push or pull on the reflector rim until it is brought into position. While one installer holds the rim, the other should tighten all the brace bolts fully. Repeat this process as required, loosening and tightening only one brace at a time.

Declination Angle Table 5.1-1			
Site Latitude	Declination°	Site Latitude	Declination°
0	0.0	47.5	6.4
10	1.5	50	6.6
20	3.0	52.5	6.9
22.5	3.3	55	7.1
25	3.7	57.5	7.3
27.5	4.0	60	7.5
30	4.4	62.5	7.6
32.5	4.7	65	7.8
35	5.0	67.5	8.0
37.5	5.3	70	8.1
40	5.6	80	8.4
42.5	5.9	90	8.6
45	6.1		

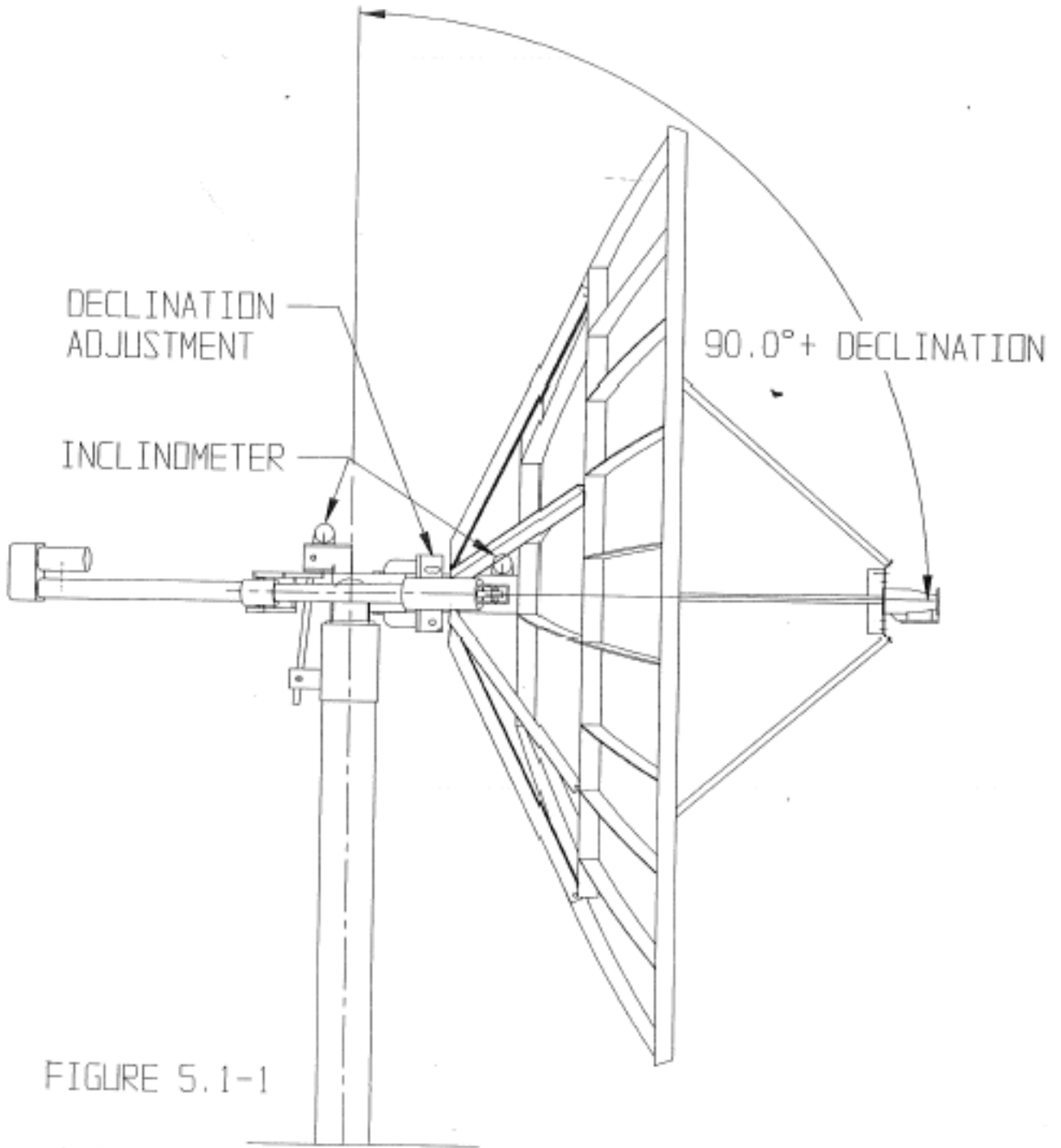

FIGURE 5.1-1

