

Thread	Max Tightening torques	
M6	8.8N.m	90Kgf.cm
M8	21.4N.m	220Kgf.cm
remark: 1N.m=10.197Kgf.cm		

20		Feedhorn(LNB) Supporting Rods
19		LNB Arm
18		Azimuth Bracket
17		Supporting Bracket Square Pole
16		Supporting Bracket
15		Reflector
9		M8*W61 U Square bolt
8		M8*65 round-head screw
7		M8*35 round-head screw
6		M8*20 round-head screw
5		M8 flange nut
4		M6 flange nut
3		M6*35 hex-cross-head cap screw w/w
2		M6*12 hex-cross-head cap screw w/w/sw
1		M6*65 hex-head cap screw
NO.	ITEM	DESCRIPTION

Note:  
  
 When assembly attention the position and direction scale there are scale beside the bracket square pole

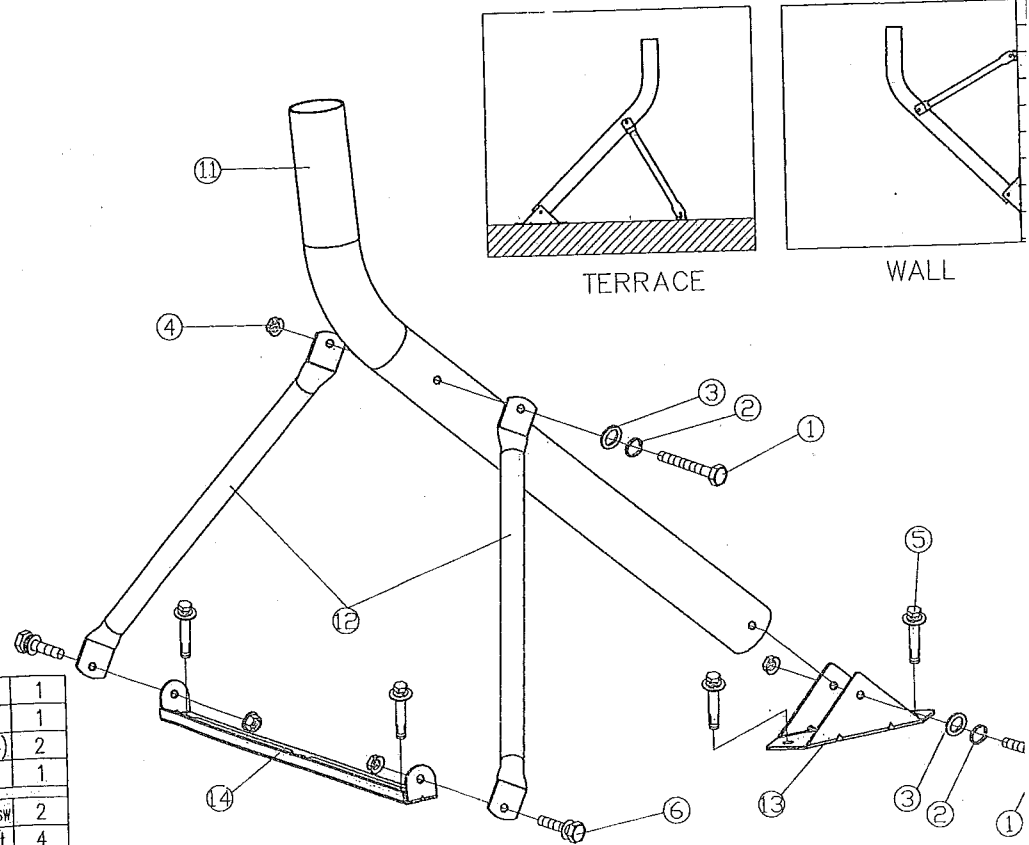

14		Mounting Stabilizer	1
13		Pipe Mount Fixer(W61)	1
12		Side Supporting Rods(ø25.4)	2
11		ø60 45° Pipe	1
6		M8*20 hex-head cap screw w/w/sw	2
5		1/4"*1-1/2" anchor bolt	4
4		M8 flange nut	4
3		M8 Washer	2
2		M8 spring Washer	2
1		M8*80 hex-head cap screw	2
NO.	ITEM	DESCRIPTION	Q'TY