

USER GUIDE

# DCH200

Standard-Definition  
Cable Receiver





## **IMPORTANT SAFETY INSTRUCTIONS**

- Read these instructions.
- Keep these instructions.
- Heed all warnings.
- Follow all instructions.
- Do not use this apparatus near water.
- The apparatus shall not be exposed to dripping or splashing and no objects filled with liquids, such as vases, shall be placed on the apparatus.
- Clean only with dry cloth.
- Do not block any ventilation openings. Install in accordance with the manufacturers instructions.
- Do not install near any heat sources such as radiators, heat registers, stoves, or other apparatus (including amplifiers) that produce heat.
- Do not defeat the safety purpose of the polarized or grounding-type plug. A polarized plug has two blades with one wider than the other. A grounding type plug has two blades and a third grounding prong. The wide blade or the third prong is provided for your safety. If the provided plug does not fit into your outlet, consult an electrician for replacement of the obsolete outlet.
- Protect the power cord from being walked on or pinched particularly at plugs, convenience receptacles, and the point where they exit from the apparatus.
- Only use attachments/accessories specified by the manufacturer.
- Unplug this apparatus during lightning storms or when unused for long periods of time.
- Refer all servicing to qualified service personnel. Servicing is required when the apparatus has been damaged in any way, such as the power-supply cord or plug is damaged, liquid has been spilled or objects have fallen into the apparatus, the apparatus has been exposed to rain or moisture, does not operate normally, or has been dropped.

## **IMPORTANT SAFETY CONSIDERATIONS**

Be sure to follow these requirements during transportation and installation.

The plug is the mains disconnect device. It shall remain readily accessible and operable.

### **During Transportation to the Subscriber Home**

Transport the cable terminal in its shipping box or an equally padded container.

Do not expose the terminal to rain or moisture.

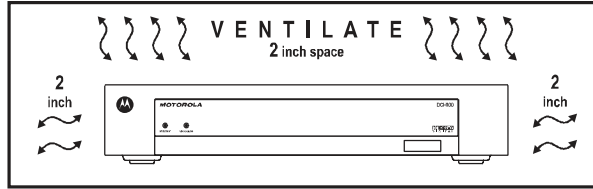

### During Installation

Do not place the cable terminal in an enclosed area where the cooling vents are blocked or impede the flow of air through the ventilation openings.

Install the terminal so that its position does not interfere with its proper ventilation. For example, do not place the terminal on a bed, sofa, rug, or similar surface that could block the ventilation openings.

Install the terminal away from heat sources such as radiators, heat registers and stoves. Installation of the terminal near consumer electronics devices, such as stereo receiver/amplifiers and televisions, is permitted as long as the air surrounding the terminal does not exceed 40 °C (104 °F).

Place the terminal on a flat surface not prone to vibration or impact.

Do not install the terminal in an area where condensation occurs.

To prevent the temporary loss of guide data and cause a temporarily non-responding terminal, do not plug the AC power cord into a switched power outlet.

### FCC COMPLIANCE

*Note: This equipment has been tested and found to comply with the limits for a Class B digital device, pursuant to part 15 of the FCC Rules. These limits are designed to provide reasonable protection against harmful interference in a residential installation. This equipment generates uses and can radiate radio frequency energy and, if not installed and used in accordance with the instructions, may cause harmful interference to radio communications. However, there is no guarantee that interference will not occur in a particular installation. If this equipment does cause harmful interference to radio or television reception, which can be determined by turning the equipment off and on, the user is encouraged to try to correct the interference by one or more of the following measures:*

Reorient or relocate the receiving antenna.

Increase the separation between the equipment and receiver.

Connect the equipment into an outlet on a circuit different from that to which the receiver is connected.

Consult the dealer or an experienced radio/TV technician for help.

**Caution:** Changes or modifications not expressly approved by Motorola for compliance could void the user's authority to operate the equipment.

This device complies with part 15 of the FCC Rules. Operation is subject to the following two conditions: (1) This device may not cause harmful interference, and (2) this device must accept any interference received, including interference that may cause undesired operation.

### **FCC DECLARATION OF CONFORMITY**

Motorola Inc., Connected Home Solutions, 101 Tournament Drive, Horsham, PA 19044, 1-215-323-1000, declares that the DCH100 receiver complies with 47 CFR Parts 2 and 15 of the FCC rules as a Class B digital device.

### **Canada Industry Canada (IC)**

This Class B digital device complies with Canadian ICES-003.

Cet appareil numérique de la classe B est conforme à la norme NMB-003 du Canada.

### **CARING FOR THE ENVIRONMENT BY RECYCLING**



When you see this symbol on a Motorola product, do not dispose of the product with residential or commercial waste.

#### **Recycling your Motorola Equipment**

Please do not dispose of this product with your residential or commercial waste. Some countries or regions, such as the European Union, have set up systems to collect and recycle electrical and electronic waste items. Contact your local authorities for information about practices established for your region. If collection systems are not available, call Motorola Customer Service for assistance.

## Software License

**IMPORTANT:** PLEASE READ THIS SOFTWARE LICENSE ("LICENSE") CAREFULLY BEFORE YOU USE ANY SOFTWARE, FIRMWARE AND RELATED DOCUMENTATION ("SOFTWARE") PROVIDED WITH MOTOROLA'S DIGITAL CABLE RECEIVER OR HOME THEATER SYSTEM (EACH SHALL BE REFERRED TO IN THIS LICENSE AS A "RECEIVER"). BY USING THE RECEIVER AND/OR USING ANY OF THE SOFTWARE, YOU INDICATE YOUR ACCEPTANCE OF EACH OF THE TERMS OF THIS LICENSE. UPON ACCEPTANCE, THIS LICENSE WILL BE A LEGALLY BINDING AGREEMENT BETWEEN YOU AND MOTOROLA. THE TERMS OF THIS LICENSE APPLY TO YOU AND TO ANY SUBSEQUENT USER OF THIS SOFTWARE.

IF YOU DO NOT AGREE TO ALL OF THE TERMS OF THIS LICENSE (I) DO NOT USE THE SOFTWARE AND (II) RETURN THE RECEIVER AND THE SOFTWARE (COLLECTIVELY, "PRODUCT"), INCLUDING ALL COMPONENTS, DOCUMENTATION AND ANY OTHER MATERIALS PROVIDED WITH THE PRODUCT, TO YOUR POINT OF PURCHASE OR SERVICE PROVIDER, AS THE CASE MAY BE, FOR A FULL REFUND.

The Software includes associated media, any printed materials, and any "on-line" or electronic documentation. Software provided by third parties may be subject to separate end-user license agreements from the manufacturers of such Software. The Software is never sold. Motorola licenses the Software to the original customer and to any subsequent licensee for personal use only on the terms of this License. Motorola and its third party licensors retain the ownership of the Software.

**You may:**

USE the Software only in connection with the operation of the Product.

TRANSFER the Software (including all component parts and printed materials) permanently to another person, but only if the person agrees to accept all of the terms of this License. If you transfer the Software, you must at the same time transfer the Product and all copies of the Software (if applicable) to the same person or destroy any copies not transferred.

TERMINATE this License by destroying the original and all copies of the Software (if applicable) in whatever form.

**You may not:**

(1) Loan, distribute, rent, lease, give, sublicense or otherwise transfer the Software, in whole or in part, to any other person, except as permitted under the TRANSFER paragraph above. (2) Copy or translate the User Guide included with the Software, other than for personal use. (3) Copy, alter, translate, decompile, disassemble or reverse engineer the Software, including but not limited to, modifying the Software to make it operate on non-compatible hardware. (4) Remove, alter or cause not to be displayed, any copyright notices or startup message contained in the Software programs or documentation. (5) Export the Software or the Product components in violation of any United States export laws.

The Product is not designed or intended for use in on-line control of aircraft, air traffic, aircraft navigation or aircraft communications; or in design, construction, operation or maintenance of any nuclear facility. MOTOROLA AND ITS THIRD PARTY LICENSORS DISCLAIM ANY EXPRESS OR IMPLIED WARRANTY OF FITNESS FOR SUCH USES. YOU REPRESENT AND WARRANT THAT YOU SHALL NOT USE THE PRODUCT FOR SUCH PURPOSES.

Title to this Software, including the ownership of all copyrights, mask work rights, patents, trademarks and all other intellectual property rights subsisting in the foregoing, and all adaptations to and modifications of the foregoing shall at all times remain with Motorola and its third party licensors. Motorola retains all rights not expressly licensed under this License. The Software, including any images, graphics, photographs, animation, video, audio, music and text incorporated therein is owned by Motorola or its third party licensors and is protected by United States copyright laws and international treaty provisions. Except as otherwise expressly provided in this License, the copying, reproduction, distribution or preparation of derivative works of the Software, any portion of the Product or the documentation is strictly prohibited by such laws and treaty provisions. Nothing in this License constitutes a waiver of Motorola's rights under United States copyright law.

This License and your rights regarding any matter it addresses are governed by the laws of the Commonwealth of Pennsylvania, without reference to conflict of laws principles. THIS LICENSE SHALL TERMINATE AUTOMATICALLY if you fail to comply with the terms of this License.

Motorola is not responsible for any third party software that is provided as a bundled application, or otherwise, with the Software or that is downloaded to, or otherwise installed on, the Product.



## U.S. GOVERNMENT RESTRICTED RIGHTS

The Product and documentation is provided with RESTRICTED RIGHTS. The use, duplication or disclosure by the Government is subject to restrictions as set forth in subdivision (c)(1)(ii) of The Rights in Technical Data and Computer Software clause at 52.227-7013. The contractor/manufacturer is Motorola, Inc., Connected Home Solutions, 101 Tournament Drive, Horsham, PA 19044.

---

© 2007 Motorola, Inc. All rights reserved. MOTOROLA and the Stylized M logo are registered in the US Patent and Trademark Office. CableCARD and M-Card are trademarks or registered trademarks of Cable Television Laboratories, Inc. Manufactured under license from Dolby Laboratories. "Dolby" and the double-D symbol are trademarks of Dolby Laboratories. Macrovision is a registered trademark of Macrovision Corporation. All other product or service names are the property of their respective owners.

No part of this publication may be reproduced in any form or by any means or used to make any derivative work (such as translation, transformation, or adaptation) without written permission from Motorola, Inc.

Motorola reserves the right to revise this publication and to make changes in content from time to time without obligation on the part of Motorola to provide notification of such revision or change. Motorola provides this guide without warranty of any kind, implied or expressed, including, but not limited to, the implied warranties of merchantability and fitness for a particular purpose. Motorola may make improvements or changes in the product(s) described in this manual at any time.

## CONTENTS



## CONTENTS

<b>1 Introduction</b> .....	1
<b>Front Panel</b> .....	2
<b>Rear Panel</b> .....	3
<b>2 Operation</b> .....	4
<b>Turning Power On and Off</b> .....	4
<b>Changing Channels</b> .....	4
<b>Adjusting the Volume</b> .....	4
<b>Interactive Program Guide</b> .....	4
<b>M-Card™</b> .....	5
<b>3 Connecting Your DCH receiver</b> .....	6
<b>Connecting Your DCH Receiver to an A/V Receiver     (Audio Only)</b> .....	7
<b>Video Connection Options</b> .....	9
<b>Connecting Your DCH Receiver to a Standard-Definition         Stereo TV</b> .....	10
<b>Connecting Your DCH Receiver to a Stereo SDTV         and Stereo VCR</b> .....	12
<b>Connecting Your DCH Receiver to an A/V Receiver,         Stereo SDTV, and Stereo VCR</b> .....	13
<b>4 Recording Your Connections</b> .....	15
<b>5 Data Features</b> .....	16
<b>6 Troubleshooting</b> .....	17

## **1 INTRODUCTION**



### **1 INTRODUCTION**

Congratulations on receiving a Motorola DCH200 Standard-Definition Cable Receiver. This User Guide introduces you to the product's basic features, outlines important safeguards, and provides several options for integrating this component into your current entertainment system. Please take a few moments to read through this User Guide as the configuration diagrams, on-screen menu description, and troubleshooting section will help you make the most of your home entertainment experience.

To determine which features of digital cable are provided in your service area, please check with your local cable operator. They will be happy to provide instructions for these optional services.

## 1 INTRODUCTION

### Front Panel

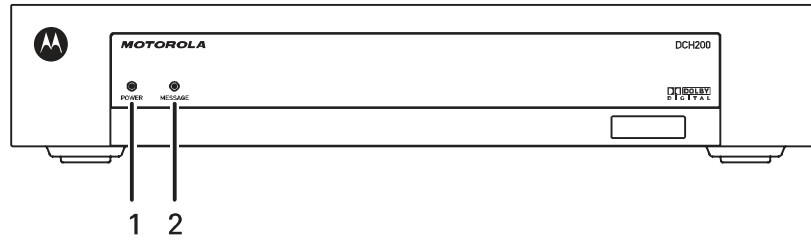

1	Power Indicator — Lit when the unit is powered ON, unlit when unit is OFF
2	Message Indicator* — Lit when a new message is waiting to be read, unlit otherwise

## 1 INTRODUCTION

### Rear Panel

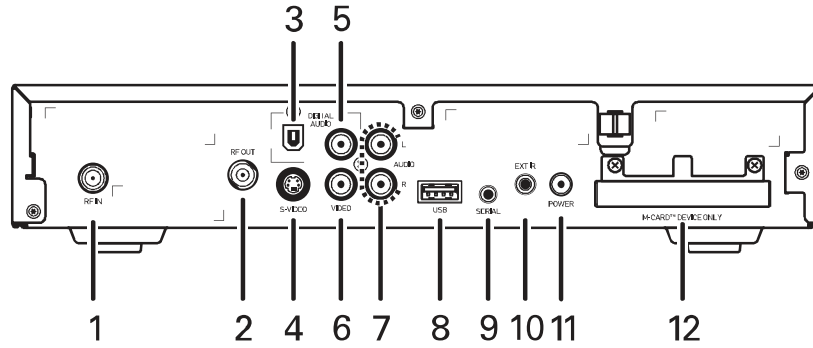

1	RF In — Connects to cable signal from your service provider
2	RF Out — Ch 3/4 modulated audio/video (SDTV) to TV or VCR
3, 5	Digital Audio (S/PDIF) — Provides Dolby® Digital 5.1 audio or PCM output
4	S-Video — Connects to S-Video (SDTV) input of TV or VCR
6, 7	Video/Audio Out — Composite video (SDTV)/audio outputs
8	USB* 1.1 — High-speed peripheral device connection
9	Serial — Service only
10	External IR connector
11	Power supply connector
12	M-Card — Inserted M-Card

*\*The availability of certain features is dependent upon application support.*

## 2 OPERATION



## 2 OPERATION

### Turning Power On and Off

Press **POWER** on the remote control to turn the DCH receiver on or off (standby). When using the remote control, be sure it is in cable mode by pressing **CABLE** before pressing **POWER**.

### Changing Channels

You can change channels in three ways:

- Press **channel +** or **-** on the remote control to step through the channel selection.
- Enter the number of the channel you wish to view using the number keys on the remote control.
- Select the channel in the interactive program guide.

### Adjusting the Volume

Press **volume +** or **-** on the remote control to adjust the volume. When you adjust the volume, the volume scale is displayed on the screen. Press **mute** on the remote control to toggle the sound on and off.

For best audio quality, use the remote control to set the DCH receiver to approximately three quarters of the maximum volume level and then adjust the audio levels on external devices such as your TV or A/V receiver.

### Interactive Program Guide

The interactive program guide displays information about TV programs and enables you to access features such as Parental Control or Pay-Per-View. Interactive program guides can vary with each cable service provider. Refer to

## **2 OPERATION**

the interactive program guide instruction manual for detailed instructions.

### **M-Card™**

The M-Card is required to view cable television programs, previously recorded programs on the DVR, or interactive on-demand programs. The M-Card should not be removed.

### 3 CONNECTING YOUR DCH RECEIVER



## 3 CONNECTING YOUR DCH RECEIVER

Instructions and diagrams are included for the following connections:

- A/V receiver (audio only)
- Stereo standard-definition TV (SDTV) (audio and video)
- Stereo SDTV and stereo VCR (audio and video)
- A/V receiver, SDTV, and VCR (audio and video)

Before you move or change components on your entertainment system, review the following:

- For basic cable connections, use 75-ohm coaxial cables equipped with F-type connectors.
- Disconnect power from your equipment before connecting or changing cable connections.

### CAUTION!



Do not place anything on top of your DCH receiver, especially other home entertainment components. Be sure to provide adequate ventilation to prevent overheating.



### **3 CONNECTING YOUR DCH RECEIVER**

#### **Connecting Your DCH Receiver to an A/V Receiver (Audio Only)**

There are three options available for audio connections to your A/V receiver:

- Digital audio (OPTICAL S/PDIF) — optical and coaxial
- Digital audio (COAXIAL S/PDIF) — optical and coaxial
- Stereo audio (AUDIO L and R)

If your A/V receiver supports it, the optical S/PDIF or coaxial S/PDIF audio outputs offer a higher level of audio quality, including support for Dolby Digital 5.1 audio, than the stereo audio outputs (AUDIO L and R).

### 3 CONNECTING YOUR DCH RECEIVER

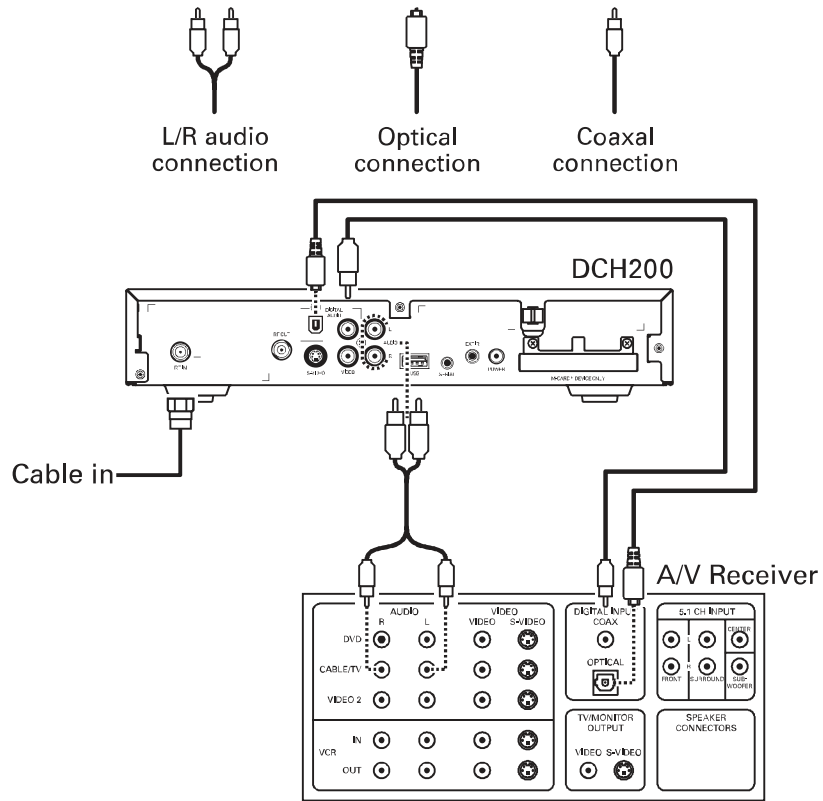

*Note: Only one audio connection is necessary.*

### **3 CONNECTING YOUR DCH RECEIVER**

#### **Video Connection Options**

The DCH receiver offers several different video connection options. Composite video, S-Video, and RF coaxial connections allow you to view standard-definition TV programming. To determine whether your TV features RF coaxial, S-Video or composite video, check the manual supplied with your TV.

Use the guidelines below to determine the best video connection for your home entertainment system.

- Use S-Video connections if your TV has an S-Video input.
- If S-Video is not available, use the composite video connection.
- If your TV has neither S-Video nor composite video inputs, use the RF Output connection and set your TV to channel 3 or 4.

### 3 CONNECTING YOUR DCH RECEIVER

#### Connecting Your DCH Receiver to a Standard-Definition Stereo TV

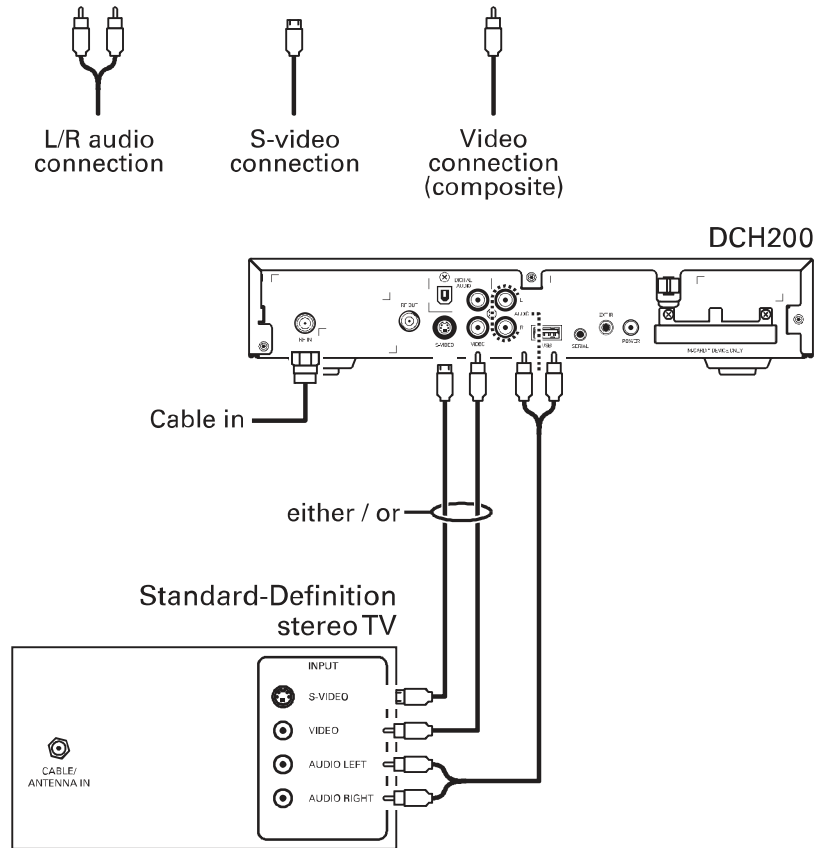

*Note: If your equipment supports it:*

- *The digital audio optical (optical S/PDIF) or digital audio coaxial (S/PDIF) audio outputs may be used in place of the stereo audio outputs (AUDIO L and R). In most cases these outputs offer a higher level of audio quality, including support for Dolby Digital 5.1 audio, than stereo audio.*

### **3 CONNECTING YOUR DCH RECEIVER**

- *S-Video connections may be used in place of the composite video connections. In most cases, S-Video offers a higher level of standard-definition video quality than composite video.*

### 3 CONNECTING YOUR DCH RECEIVER

#### Connecting Your DCH Receiver to a Stereo SDTV and Stereo VCR

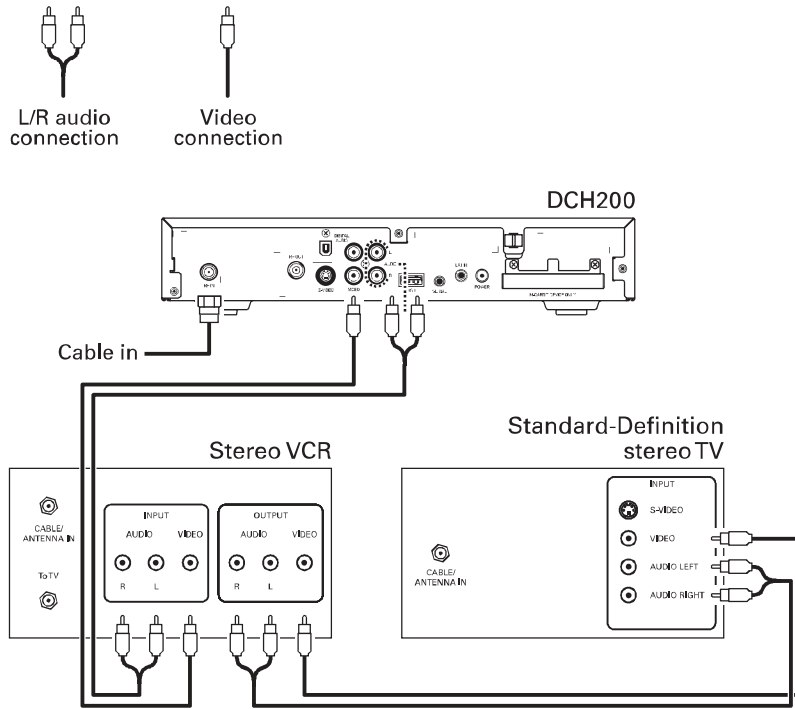

*Note: If your equipment supports it:*

- The digital audio optical (optical S/PDIF) or digital audio coaxial (S/PDIF) audio outputs may be used in place of the stereo audio outputs (AUDIO L and R). In most cases these outputs offer a higher level of audio quality, including support for Dolby Digital 5.1 audio, than stereo audio.
- S-Video connections may be used in place of the composite video connections. In most cases, S-Video offers a higher level of standard-definition video quality than composite video.

### 3 CONNECTING YOUR DCH RECEIVER

#### Connecting Your DCH Receiver to an A/V Receiver, Stereo SDTV, and Stereo VCR

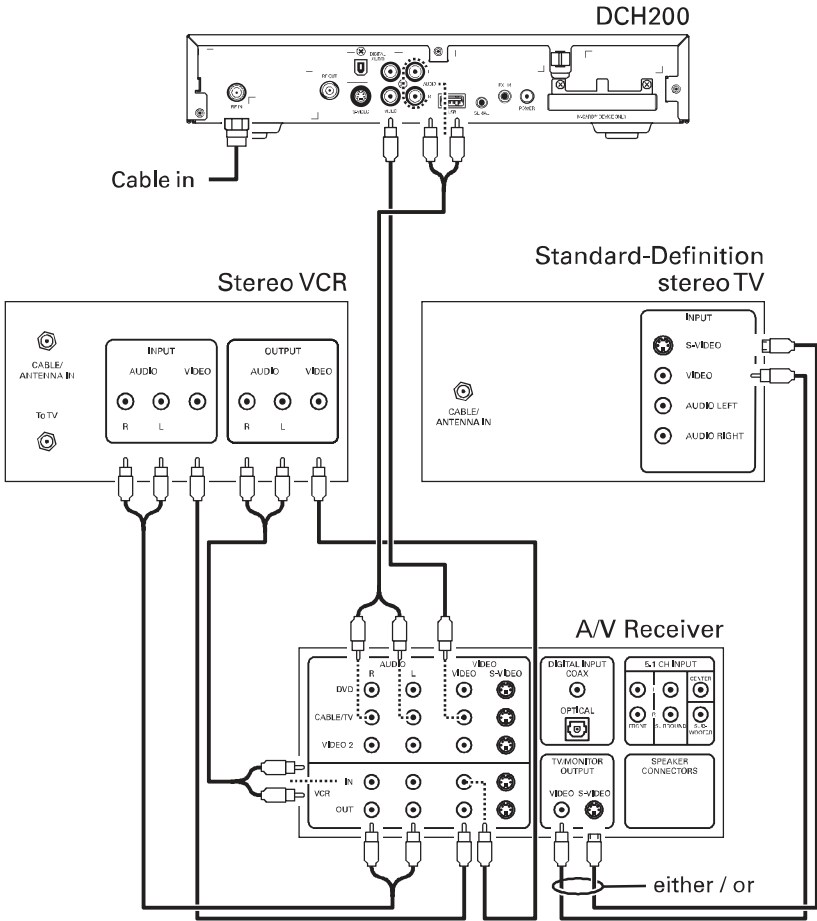

### **3 CONNECTING YOUR DCH RECEIVER**

*Note: If your equipment supports it:*

- *The digital audio optical (optical S/PDIF) or digital audio coaxial (S/PDIF) audio outputs may be used in place of the stereo audio outputs (AUDIO L and R). In most cases these outputs offer a higher level of audio quality, including support for Dolby Digital 5.1 audio, than stereo audio.*
- *S-Video connections may be used in place of the composite video connections. In most cases, S-Video offers a higher level of standard-definition video quality than composite video.*



## 4 RECORDING YOUR CONNECTIONS



### 4 RECORDING YOUR CONNECTIONS

Use this diagram to record connections between your home entertainment components. You can use this diagram to reconnect your system if you move the equipment or add new equipment.

Disconnect the power from the DCH receiver before connecting or changing cable connections. Do not place another component or object on top of the DCH receiver.

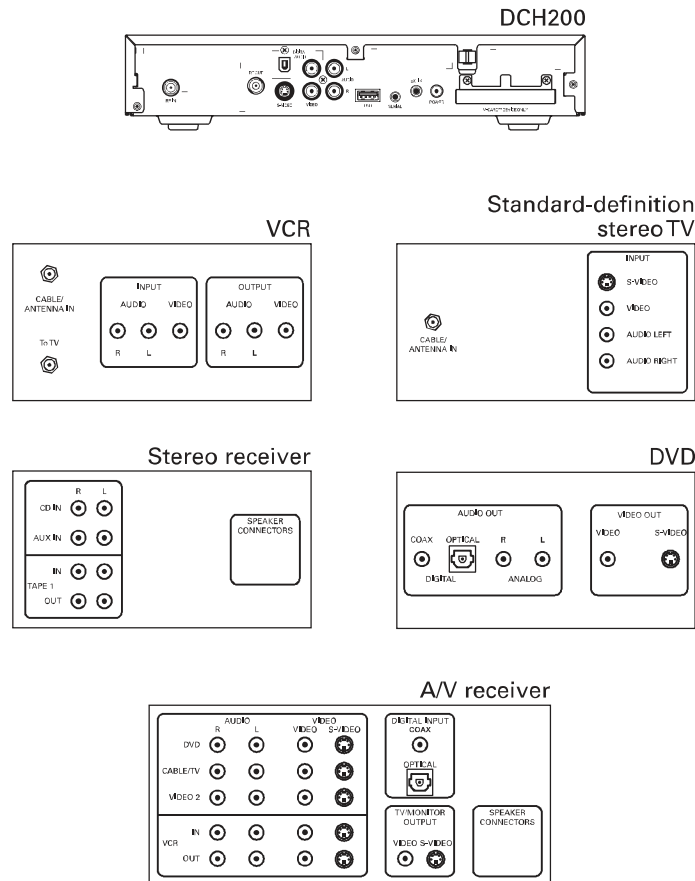

## 5 DATA FEATURES



### 5 DATA FEATURES

In addition to high-quality audio and video, the DCH200 provides a USB 1.1 port for connections to external peripheral devices. Its functionality requires specific application software and services offered by your cable provider.

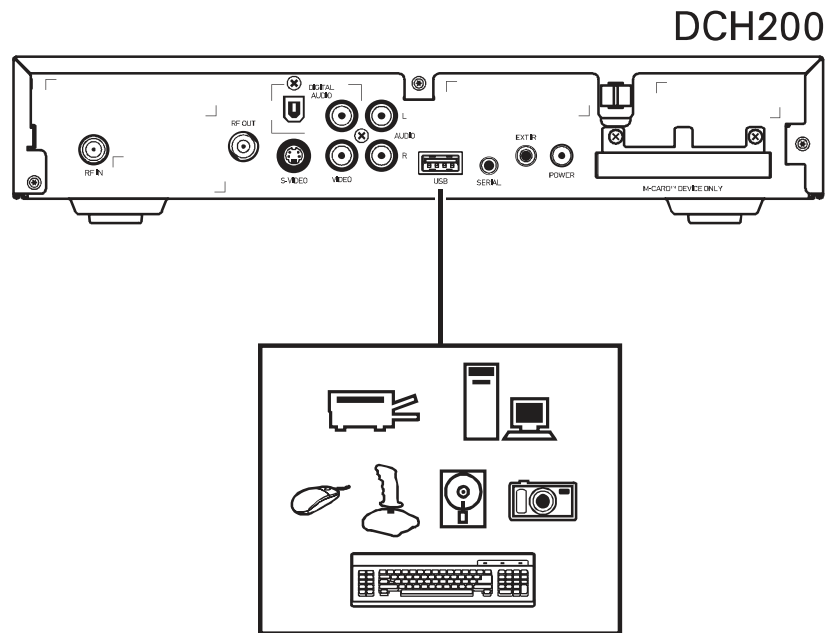

### USB devices

*Note: Do not attempt to connect data devices to your DCH receiver without contacting your cable provider. Advanced data features require the proper application and network infrastructure to operate.*

## 6 TROUBLESHOOTING



### 6 TROUBLESHOOTING

Before calling your cable provider, review this troubleshooting guide.

<b>Problem</b>	<b>Possible Solutions</b>
The DCH receiver will not power on.	<ul style="list-style-type: none"><li data-bbox="570 621 1243 758">• The DCH receiver may have received a software update and may not power on while the new software is being installed. Try again in a few minutes.</li><li data-bbox="570 764 1243 903">• Verify that the power supply is connected to the DCH receiver and an AC outlet. Unplug the DCH power supply cord from the AC outlet, plug it back in, and then press the POWER button.</li><li data-bbox="570 909 1243 1104">• If the DCH receiver is connected to a switched outlet on another unit, verify that that unit is powered on. Unplug the DCH power supply cord from the AC outlet, plug it back in, and then press the POWER button. Use of an unswitched outlet is recommended.</li></ul>

## 6 TROUBLESHOOTING

Problem	Possible Solutions
The remote control does not work.	<ul style="list-style-type: none"> <li>• Verify that the remote control is in “Cable” mode.</li> <li>• Verify that there are no obstructions between the remote control and the DCH receiver. Aim the remote control directly at the DCH receiver front panel, not the TV or VCR.</li> <li>• If using an external IR sensor connected to the EXT IR input on the rear panel, ensure the cable is properly connected to the rear panel input and that there is a clear line-of-sight from the remote to the sensor.</li> <li>• The angle between the remote control and the DCH receiver may be too large. Stand in front of the DCH receiver and not too far to either side.</li> <li>• Press and release operation keys one at a time, firmly and deliberately.</li> <li>• Check the batteries in the remote control. Install new batteries if needed.</li> </ul>
There is no audio when viewing cable channels.	<ul style="list-style-type: none"> <li>• Verify that the Mute button on the remote control has not been pressed. Press <b>mute</b> on the remote control to restore sound.</li> <li>• If the DCH receiver audio output is connected to the TV, verify that the Mute button on the TV has not been pressed.</li> <li>• If the DCH receiver audio output is connected to a home theater receiver, verify that the receiver is set to the appropriate input source and the Mute button on the receiver has not been pressed.</li> <li>• Verify that you have the correct cables for the audio connections.</li> <li>• Verify that the audio cables are firmly connected between the DCH receiver and the audio playback device (TV, receiver, DVD player, etc.).</li> </ul>

## 6 TROUBLESHOOTING

Problem	Possible Solutions
<p>There is no audio from the center and/or surround speakers of a home theater receiver connected to the DCH receiver.</p>	<ul style="list-style-type: none"> <li>• Not all Dolby Digital® programs feature full 5.1 surround sound. In some cases, the programs may only contain left and right stereo audio.</li> <li>• Verify that the S/PDIF cable (coaxial or optical) is firmly connected to the DCH receiver and the home theater receiver.</li> <li>• Verify that the home theater receiver is set to a surround sound audio mode (Dolby Digital, Dolby Pro Logic II®, Dolby Pro Logic®).</li> <li>• Verify that the receiver is properly configured to work with all connected speakers.</li> </ul>
<p>There is no video on the TV screen.</p>	<ul style="list-style-type: none"> <li>• Verify that the TV is powered on and set to the appropriate input source for the DCH receiver.</li> <li>• Verify that the DCH receiver is powered on and tuned to an authorized cable channel.</li> <li>• Verify that all video cables between the DCH receiver and the TV are firmly connected.</li> <li>• Verify that the coaxial cable feed is firmly connected to the DCH receiver and the wall jack.</li> <li>• If the DCH receiver video output is connected to a home theater unit, verify that the home theater unit is powered on and set to the appropriate input source.</li> </ul>
<p>No closed captions display.</p>	<ul style="list-style-type: none"> <li>• Verify that closed captions are enabled on the TV.</li> <li>• Closed captioning may not be available on the current program.</li> </ul>
<p>There are black bars to the right and left of the picture.</p>	<ul style="list-style-type: none"> <li>• Wide-screen TVs display 4:3 programs in this format unless set to Stretch (see your TV manual for information about stretching 4:3 video).</li> </ul>
<p>There are black bars above and below the picture.</p>	<ul style="list-style-type: none"> <li>• Some SD programs are broadcast in the letterbox format with black bars above and below the picture. Some wide-screens TVs offer a zoom feature that may be able to remove the black bars (see your TV manual for information about zooming 4:3 video).</li> </ul>

## 6 TROUBLESHOOTING

<b>Problem</b>	<b>Possible Solutions</b>
There are black bars on all four sides of the picture.	<ul style="list-style-type: none"><li>• This may occur on a 16:9 TV if the active video for an SD broadcast is in letterbox format. To confirm, wait for a commercial or look for a graphic, such as a network logo. If the commercial fills the screen from top to bottom, or the graphic appears below the active video, the program is being letterboxed by the broadcaster. You can minimize this by activating the zoom feature on the TV.</li><li>• A broadcaster may include black bars on either side of a wide screen broadcast. This is called a "hybrid" aspect ratio and results in a black border surrounding the video on a 4:3 TV. Because this is part of the broadcast, the DCH200 cannot correct the video. You may be able to minimize the border using the zoom feature on the TV.</li></ul>





**MOTOROLA**

Motorola, Inc.  
101 Tournament Drive  
Horsham, PA 19044 U.S.A.

<http://www.motorola.com>

537453-001-c  
04/07